

Modellname / Model name / Nom du modèle / Modellnamn / Nome modello / Název modelu / Modelnaam / Ime modela / Numéro Modelo / Modell neve / Название модели / Názov modelu / Ime modela / Denumire model / Наименование на модела / Nazwa modelu

Toreto

Type / Tipo / Tipus / Typ / Тип / Tip

SU-80

Farbe / Color / Couleur / Kolor

BIAŁY

CASHMERE

31.07.24

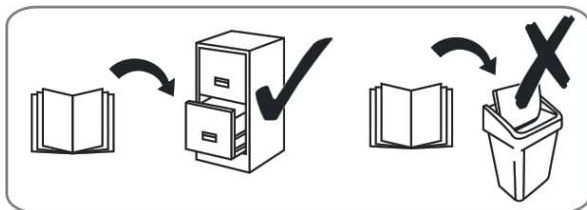
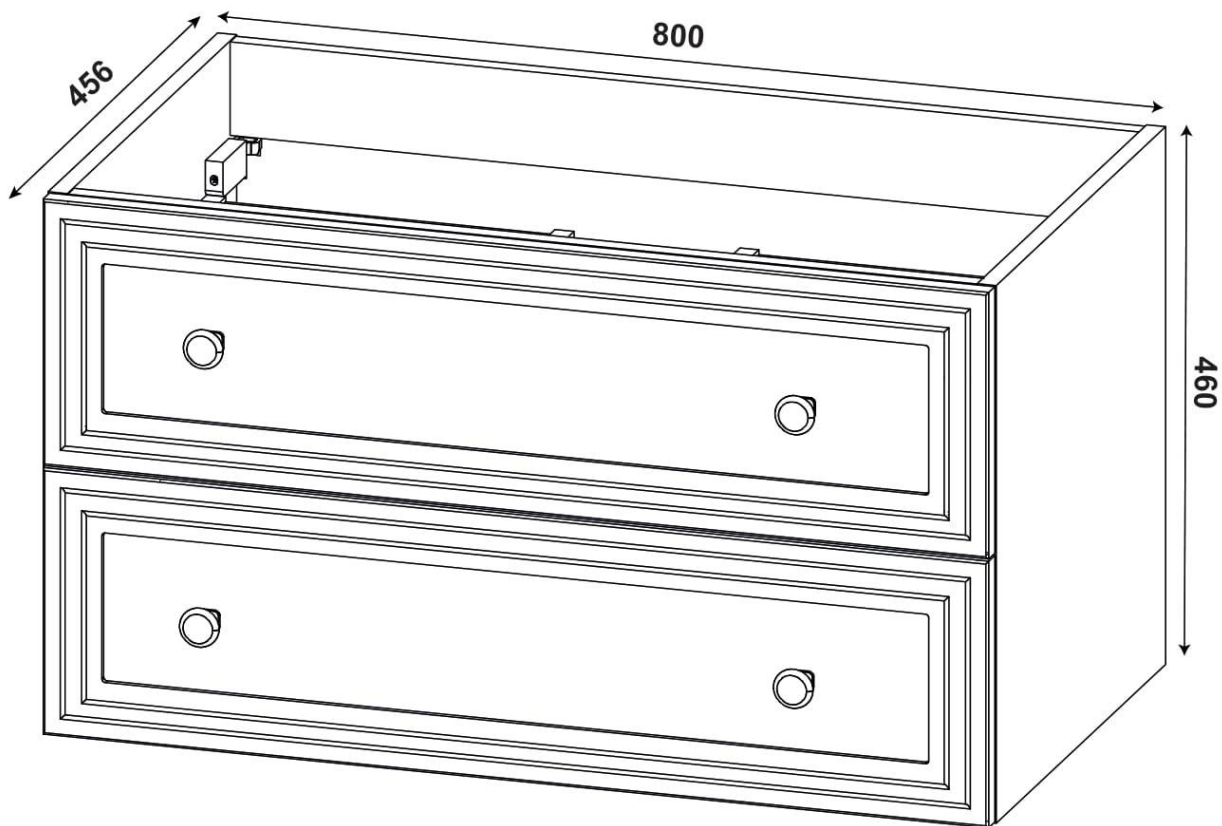
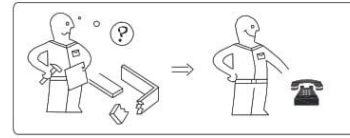
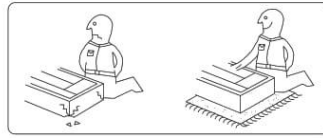
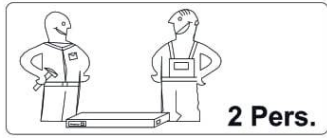

Wichtig - Für spätere Verwendung aufbewahren - sorgfältig lesen!

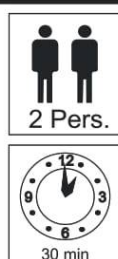
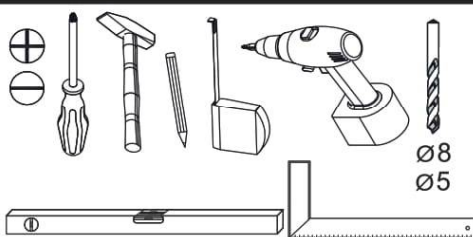

- festziehen / tighten / Затягивать / serrer / stringere / utáhnout / vasttrekken / zategnuti / strângere / zwiázac / zacisnąć / szorosan meghúzni / pevne dotiahnuť / trdno pritegniti / затянуть / dra át
- eindrücken / press in / enfoncer / wcisnąć / ribattere / zatlačit / Вкайрите / indrukken / benyomni / stlačit / vtisniti / tryck in / introducere prin apăsare / вдавить
- ausmessen / measure / mesurer / misurare / opmeten / izmeriti / miera / kimérni / izmeriti / măsurare / измерить / změřit / Измерете / mät upp / zmierzyc

- drücken / press / presser / stisknout / Натиснете / vtisniti / nasinac / drukken / pritisnuti / nacinac / pritisniti / нажать / (meg)nyomni / apăsare / tryck fast / nacinşac
- einschlagen / hammer in / beverni / sla in / frapper au marteau / infossare / Zabit' / zaražit / Набийте / zabiti / wbici / introducere prin bătaie / забить / zatlout
- Drehen - wenden / przekreślić - odwrócić / Keren - omdraalen / Girare - Ruotare / Okrenuti - ubnuti / Retourner - renverser / Turn over - turn around / Otolce - obratite / Завъртете - обърнете / Obrnite list / Intoarceți - rotiți / Vrid runt - vänd / прокрутить - повернуть / otočit - obrátit / elforgatni - megfordítani

Modell name/Model name/Nom du modele/Modellnamn
Nome modello/Název modelu/Modelnaam/Ime modela
Número Modelo/ Modell neve/ Название модели /
Názov modelu/Ime modela/Denumire model/
Наименование на модела /Nazwa modelu

Toreto

Type / Tipo / Tipus / Typ / Тип / Tip

SU-80

Farbe / Color / Couleur / Kolor

BIAŁY

CASHMERE

D Unser Direktservice für Beschlagteile
Sollte Ihnen ein Beschlagteil fehlen, können Sie diese Servicekarte direkt an die untenstehende Adresse mailen. Wir können allerdings nur Beschlagteile auf diesem Wege verschicken. Sollten Sie eine andere Beanstandung an Ihrem Möbelstück haben, so wenden sie sich bitte direkt an Ihr Möbelhaus.

GB Our direct order service for fitting
If a fitting part is missing, you can e-mail this service card directly to the address below. However, we can only send fitting parts in this way. If you have any other cause for complaint concerning your item of furniture, please contact your furniture store directly.

CZ Naše přímé služby pro kování
Chybí-li vám nějaký díl z kování, můžete tuto servisní kartu odeslat e-mailem přímo níže uvedenou adresu. Touto cestou však můžeme rozeslat jen díly kování. Pokud byste reklamovali jiný díl nábytku, obraťte se přímo na svého prodejce nábytku.

F Bien étudier la notice de montage
Si l'un vous manque une ferrure, veuillez envoyer directement la présente carte service à l'adresse e-mail indiquée ci-dessous. Cependant, ceci nous permet uniquement d'envoyer des ferrures. Pour tout autre type de réclamation concernant votre meuble, veuillez contacter directement votre magasin d'ameublement.

I Il nostro servizio diretto per l'ordine della ferramenta
Qualora Vi dovesse mancare un pezzo di fissaggio, allora Vi preghiamo di inviare questa carta di servizio immediatamente all'indirizzo sottostante. Possiamo inviare i pezzi di fissaggio solamente per mezzo di questo procedimento. Qualora dovesse avere qualche altra reclamazione in merito al mobile, allora Vi preghiamo di rivolgerVi direttamente al Vostro Negozio di mobili.

BG Нашата директна услуга за обков
Ако липсват части от комплекта, попълнете настоящата сервисна карта и ни я изпратете на e-mail адреса, посочен по-долу. По този начин можем да доставяме само липсващи елементи от обкова. Ако установите други дефекти по мебелите, Ви съветваме да се обърнете към мебелната къща/магазин, от който сте закупили стоката.

NL Onze directservice voor losse onderdelen
Vanneer er een onderdeel ontbreekt, kunt u deze servicekaart direct aan onderstaand e-mailadres sturen. Wij kunnen langs deze weg echter alleen beslagdelen versturen. Mocht u een ander probleem aan uw meubel hebben, verzoeken wij u contact op te nemen met uw meubeldealer.

PL Nasz bezpośredni serwis części montażowych
Jeżeli brakuje części koniecznych do montażu, prosimy o przesłanie nam niniejszej karty serwisowej na poniższy adres e-mailowy. W ten sposób możemy przesłać Państwu tylko brakujące części. W przypadku innych reklamacji dotyczących mebla, prosimy zgłosić się do salonu meblowego, w którym został dokonany zakup.

HR Servis za okove
U slučaju da nedostaje neki od dijelova molimo vas da na dolje navedenu mail adresu pošaljete ovaj servisni obrazac. Na ovaj način mogu se dostaviti samo okovi. U slučaju da imate dodatne prigovore vezane uz komad namještaja molimo vas da se obratite izravno trgovini namještaja gdje je isti kupljen.

HU Direktszolgáltatunk vasalatok esetén
Ha hiányzik egy vasalat, ezt a kártyát közvetlenül elküldheti az alább található címre. Azonban csakis vasalatókat tudunk így küldeni. Amennyiben másfajta reklamációt áll fenn bűtorárbját illetően, forduljon közvetlenül a bűtorházhöz.

SK Naš priamy servis pre časti kovania
Ak by Vám chýbala nejaká časť kovania, môžete poslať túto servisnú kartu poslať e-mailom na nižšie uvedenú adresu. Diely kovania vieme poslať iba týmto spôsobom. Ak by ste mali inú reklamáciu ohľadom Vášho nábytku, obráťte sa priamo na Vašu predajňu nábytku.

SLO Naše direktne uslužne storitve za okovje
Če vam manjka kakšno okovje, lahko to servisno kartico pošljete po e-pošti direktno na spodnji naslov. Po tej poti vam lahko pošljemo samo okovje. Če želite reklamirati kakšen drug del pohištva, se obrnite neposredno na vašo trgovino pohištva.

RO Service-ul nostru direct pentru feronerie
In cazul in care va lipsesete o piesa de feronerie puteti sa trimiteți direct acest card de service prin e-mail la adresa de mai jos. Noi nu putem expedia piese de feronerie decât pe această cale. Dacă aveți o altă reclamație referitoare la piesa de mobilier, atunci vă rugăm să vă adresați direct la magazinul dvs. de mobilă.

RUS Наш прямой сервис для поставок фурнитуры
Если окажется, что Вам не хватает того или иного элемента фурнитуры, Вы можете отправить сервисную карту по факсу непосредственно на нижеприведенный адрес электронной почты. Однако, таким образом мы можем переслать лишь фурнитуру. Если же у Вас возникнут иные претензии относительно приобретенной мебели, пожалуйста, обращайтесь непосредственно в организацию, осуществившую продажу.

S Vår direktservice för beslagsdelar
Om du saknar en beslagsdel kan du skicka detta servicekort direkt till e-postadressen som anges nedan. Tänk på att detta är den enda möjligheten att skicka beslagsdelar till dig. Om du vill reklamera din möbel av en annan anledning måste du kontakta ditt möbelhus direkt.

ES Nuestro servicio directo para accesorios
Si le falta algún accesorio, puede enviar esta tarjeta de servicio directamente a la siguiente dirección. No obstante, por este método solo podemos enviar accesorios. Si tiene alguna otra objeción sobre su mueble, consulte directamente con su mueblería.

TR Donatılar için doğrudan servisimiz
Bir donatınız eksikse bu servis kartını doğrudan aşağıda bulunan adrese doğrudan mail yazabilirsiniz. Sadece bu yolla donatıları gönderilebilir. Mobilyanızda başka şikayetleriniz varsa lütfen doğrudan mobilya satıcınıza danışın.

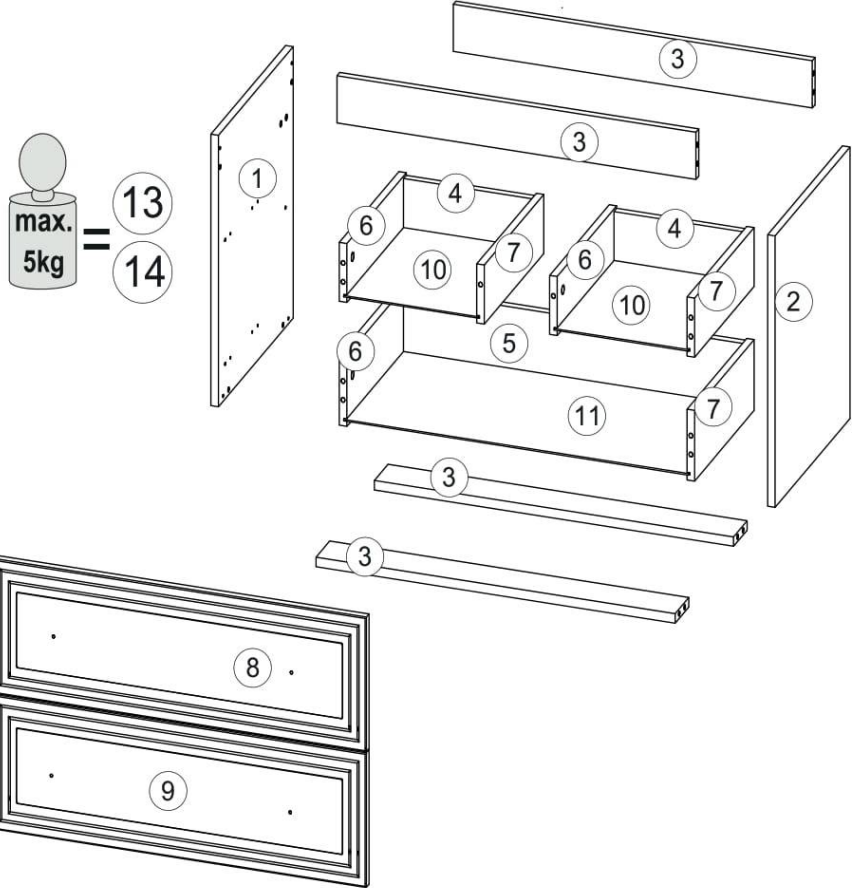

Nr.	Size mm			Box	Pieces
1	460	440	16	1/1	1
2	460	440	16	1/1	1
3	768	80	16	1/1	4
4	278	74	16	1/1	2
5	728	74	16	1/1	1
6	350	90	16	1/1	3
7	350	90	16	1/1	3
8	798	228	18	1/1	1
9	798	228	18	1/1	1
10	288	354	3	1/1	2
11	738	354	3	1/1	1
B1				1/1	1

Grund der Beanstandung / Cause for complaint:

Möbelhaus / Furniture store:

Kunde / Customer: _____ Telefon / Telephone: _____

PLZ / Postcode: _____ Ort / City: _____

Str.+Nr. / Street address _____

@E-Mail: _____

E-Mail Kundenservice / Customer service e-mail / E-mail servisního střediska / E-mail de notre service clientèle / e-mail servizio clienti / E-mail на отделе за обслужване на клиенти / E-mail klantenservice / E-mail servisu dla klientów / Servisna mail adresa / Az ügyfélszolgálat e-mail címe / E-mail zákaznického servisu / E-pošta Servisna služba / E-mail Serviciu clientj / E-Mail сервисной службы / Servicio de atención por correo electrónico / Müşteri hizmetleri e-postası

Modell name/Model name/Nom du modele/Modellnamn
 Nome modello/Název modelu/Modelnaam/Ime modela
 Numéro Modelo/ Modell neve/ Название модели /
 Názov modelu/Ime modela/Denumire model/
 Наименование на модела /Nazwa modelu

Toreto

Type / Tipo / Tipus / Тип / Тип / Tip











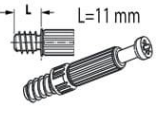

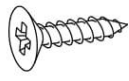
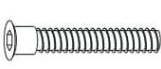

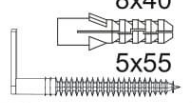
SU-80

Farbe / Color / Couleur / Kolor

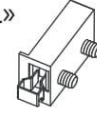
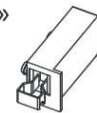
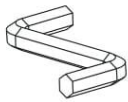
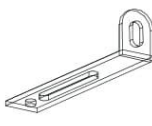
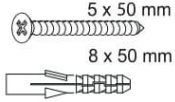
BIAŁY

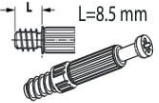
CASHMERE

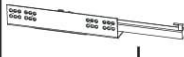
B1

 C2 x12	 C7 x14	 D5 x14	 B1 x12	 A0/1 x14	 E1 x2
 C0/4 x14	 B0/3 x12	 M1 x8	 P26/1 x1	 P26/2 x1	 K x1
 P0 x2	 E0 x2	 D36 x18	 P93 x1	 C2/1 x2	 D20 x16
 N14R x2	 N14L x2	 L201 x4			

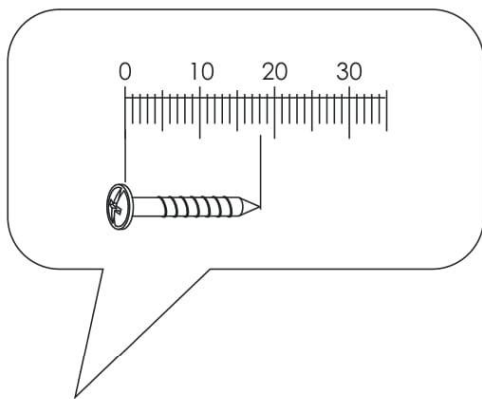

Değerli müşterimiz, evde kullanılmak üzere tasarlanan iç mekan programımızdan bir mobilya satın aldığınız için teşekkür ederiz. Lütfen teslimat kapsamının eksiksiz olup olmadığını kontrol edin ve montajdan önce aşağıdaki önemli bilgileri dikkatlice okuyun ve daha sonra üçüncü şahıslar tarafından da kullanılacak üzere saklayın.

Mobilyalarınız amaçlandığı şekilde kullanılmalıdır. Amacı dışında kullanımı, maddi hasarlara veya bazı durumlarda kişisel yaralanmalara neden olabilir. Mobilyalar çocuk oyuncakları değildir. Üretici veya satıcı, amacı dışında veya yanlış kullanımdan kaynaklanan hasarlar için hiçbir sorumluluk kabul etmez.

D I K K A T: Çocuklar veya zihinsel engelli kişiler, yaralanma ve/veya bozulma riski bulunduğu için, mobilya parçalarından, sivri uçlu nesnelere, küçük parçalardan ve ambalaj malzemelerinden daima uzak tutulmalıdır.

M O N T A J: Montaj sırasında lütfen işletim, kullanım, kurulum veya montaj talimatlarınıza uyun ve uyan ve güvenlik talimatlarına özellikle dikkat edin. Talimatlara uyulmaması, kişisel yaralanmaya veya mobilya hasarına/güvenliğine riskine neden olabilir. Montaj / kurulum konusunda zorluk yaşıyorsanız, lütfen servis ekibimize iletişime geçin. Ekibimiz tavsiyelerle ve destekleriyle size yardımcı olacaktır. Montaj sadece uzman kişiler tarafından yapılmalıdır. Ürün/ürün parçalarında değişiklikler, üreticiden/satıcıdan gelmeyen parçalarla/sarf malzemeleriyle değiştirilmesi veya kullanılması durumunda meydana gelebilecek hasarlar için sorumluluk kabul edilmez.

Ürünleri dübel ve vida gibi duvara sabitleme araçları kullanılmıyorsa, bunlar sadece sağlam ve tek tip malzemelerden yapılmış duvarlarda kullanılmak üzere tasarlanmıştır. Bir bağlantı sadece bağlantı elemanı ve duvar arasındaki bağlantı kadar iyidir. Lütfen mobilyayı sabitlemeden önce duvarınızın hem ayakta hem de asılı mobilya için uygunluğunu kontrol edin ve sadece uygun bağlantı elemanları kullanın. Olası bir delme işleminden önce delme alanında testisat olmadığının emin olun. Sonuçta, montajı yapan kişi duvara sabitlemekten sorumludur.

Bu aynı zamanda elektrikli parçaların ve diğer yapsal aksesuarların montajı için de geçerlidir. Elektrikli parçaların ve diğer inşaatla ilgili aksesuarların montaj/kurulumunu sadece yetkili uzman personel tarafından yapılabilir. Tüm elektrik ve yapsal kurulumlar, eyaletimizdeki geçerli standartlara ve güvenlik yönetmeliklerine uygun olarak yapılmalıdır. Işık kaynakları için lütfen sadece izin verilen aydınlatma güçlerini kullanın. Maksimum Watt değerine uyulmaması durumunda aşırı ısınma nedeniyle yangın riski söz konusudur. Yangın tehlikesi nedeniyle aydınlatmaların üstünü kapatmak yasaktır.

Mobilyaların düzgün fonksiyonu sadece düz ve yatay zeminde garanti edilir. Kapılar önceden ayarlanmıştır, ancak yerel koşullar nedeniyle yeniden hizalanması/ayarlanması gerekebilir. Lütfen maksimum yükte ilgili açıklık bilgilerine uyun. Mobilyaların üzerine çıkılması yasaktır. Yanlış kullanılan mobilyaların devrilmesine neden olabilir. Bunu önlemek için mobilyaları her zaman devrilmeye karşı emniyetle alınmalıdır. Aşırı yük/aşırı zorlama durumunda (özellikle oyun oynayan çocuklar, insanlar, malzeme veya diğer uygunsuz eşyalar nedeniyle) kırılma ve yaralanma riski söz konusudur. Kalkıcı sağlamlığı güvenceye almak için tüm vidalar ve yük taşıyan bağlantı noktaları 5-6 hafta sonra tekrar kontrol edilmelidir.

B A K I M:
-Mobilya bakımıyla ilgili notlar-
Ürününüzün keyfini alabildiğince uzun süre çıkarabilmemiz için lütfen uygun mobilya bakımıyla ilgili talimatlarımıza dikkate alın.
Temizlik sırasında temiz, kuru ve yumuşak pamuklu bir bez kullanın. Mobilyanızın kapsamlı bir temizliğe ihtiyacı varsa, bezi biraz su veya mobilya temizleyicisiyle nemlendirebilir ve ardından temizlenen eşyaları kurutabilirsiniz. Metal ve cam parçaları, üzerlerindeki bakım talimatlarına göre piyasada bulunan metal ve cam temizleyicilerle en iyi şekilde temizleyebilirsiniz. Temizlik maddeleri, mobilya temizliği için uygun olduklarını açık bir göstergesini taşımazlar.
Hiçbir koşulda buharlı temizleyiciler, kostik, aşındırıcı veya etkilere aşırı olmadığınız diğer maddeleri kullanmamalısınız.

D I K K A T: Çok parlak yüzeyler teslimat sırasında koruyucu bir folyoyla korunur. Bunu tamamen monte edilene ve tozu temizlenene kadar mobilya üzerinde bırakın. Koruyucu folyonun çıkarıldığı çok parlak elemanlar ancak 72 saat sonra temizlenebilir ve kullanılabilir (ortam havasındaki son katlaşma süresi). Yüzelere keskin nesnelere zarar vermemeyi ve asla güçlü güneş ışığına maruz bırakmayın.

T A S F İ Y E
-Tasfiyeyle ilgili notlar-
Çevre için lütfen ürüne göre ayrılmış ambalaj atıklarını doğaya değil, bunlar için sağlanan atık/geri dönüşüm kutularında tasfiye edin.
Hasarlı veya kullanılmayan mobilyalar, her bir parçanın geri dönüştürülmesi için özel geri kazanım tesislerine gönderilebilir.
Artık kullanılmayan ancak hala işlevsel olan mobilyaların hemen tasfiye edilmesi gerekmez. Bunları örneğin hayır kurumlarına bağışlayın.

Yeni mobilyalarınızı güle güle kullanın.

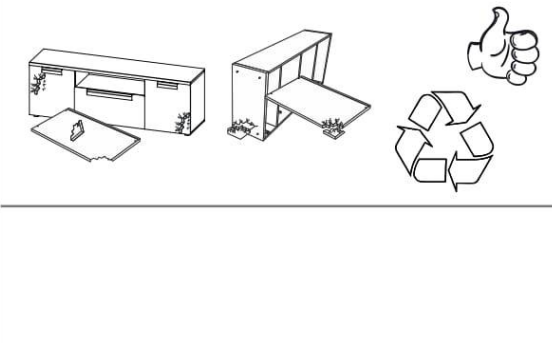
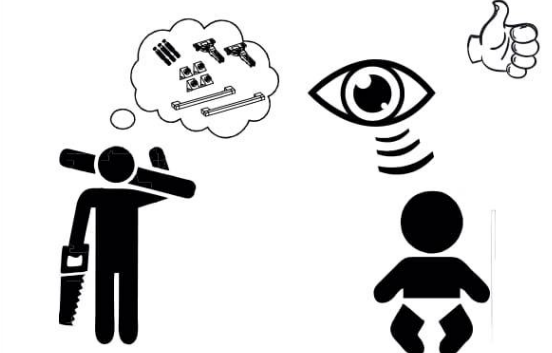
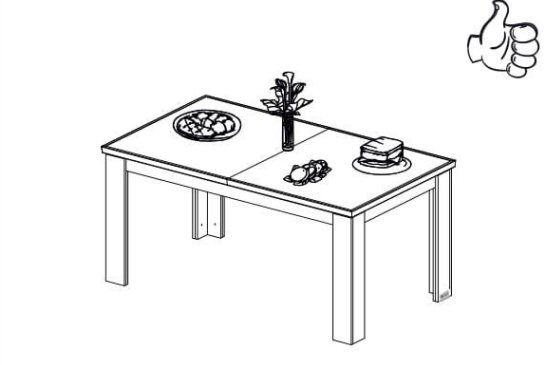
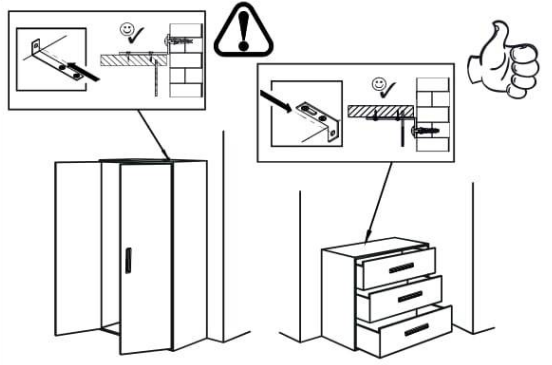
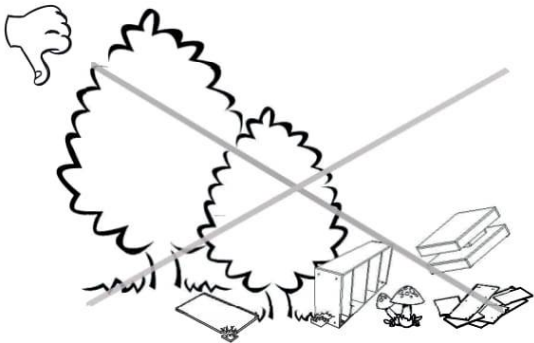
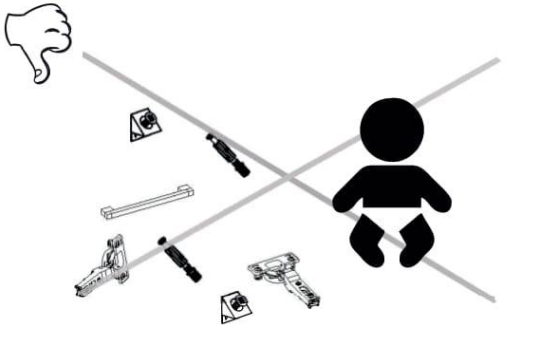
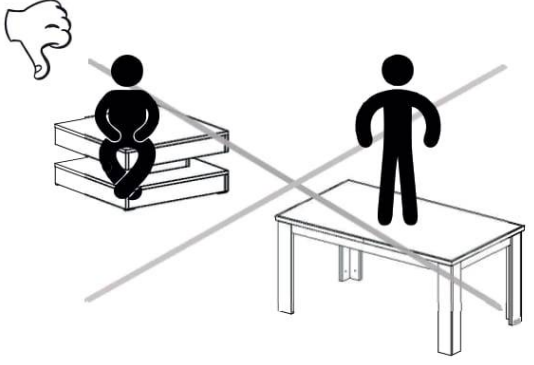
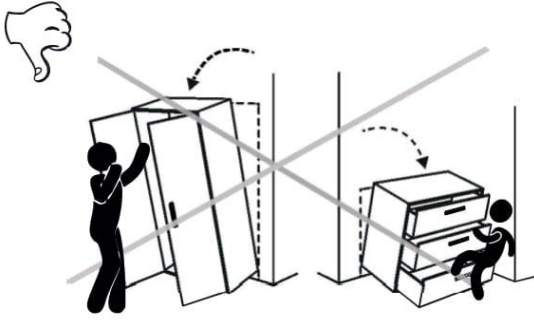

1

- C2 x8
- P26/1 x1
- P26/2 x1
- D20 x16
- 5x9
- N14
- L-350 L x2
- L-350 R x2

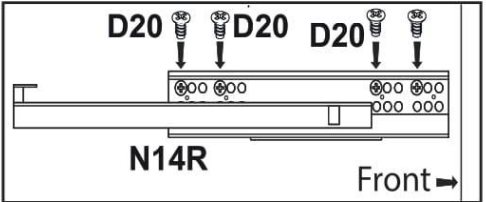
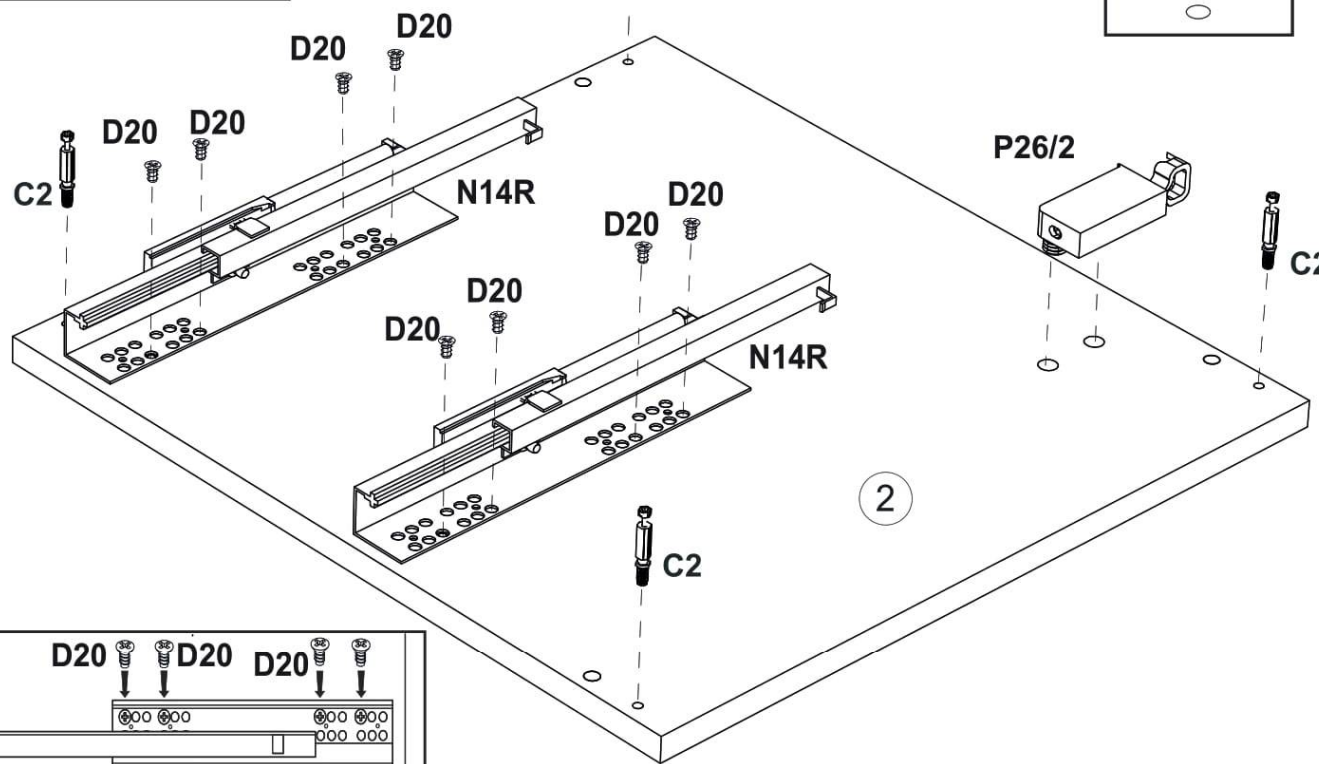
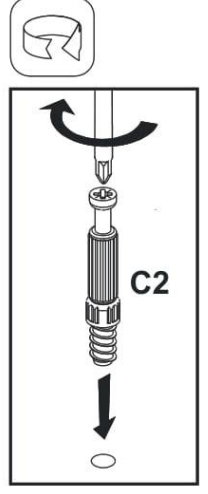
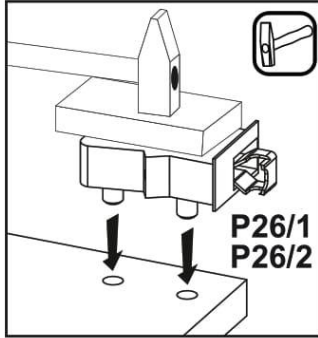
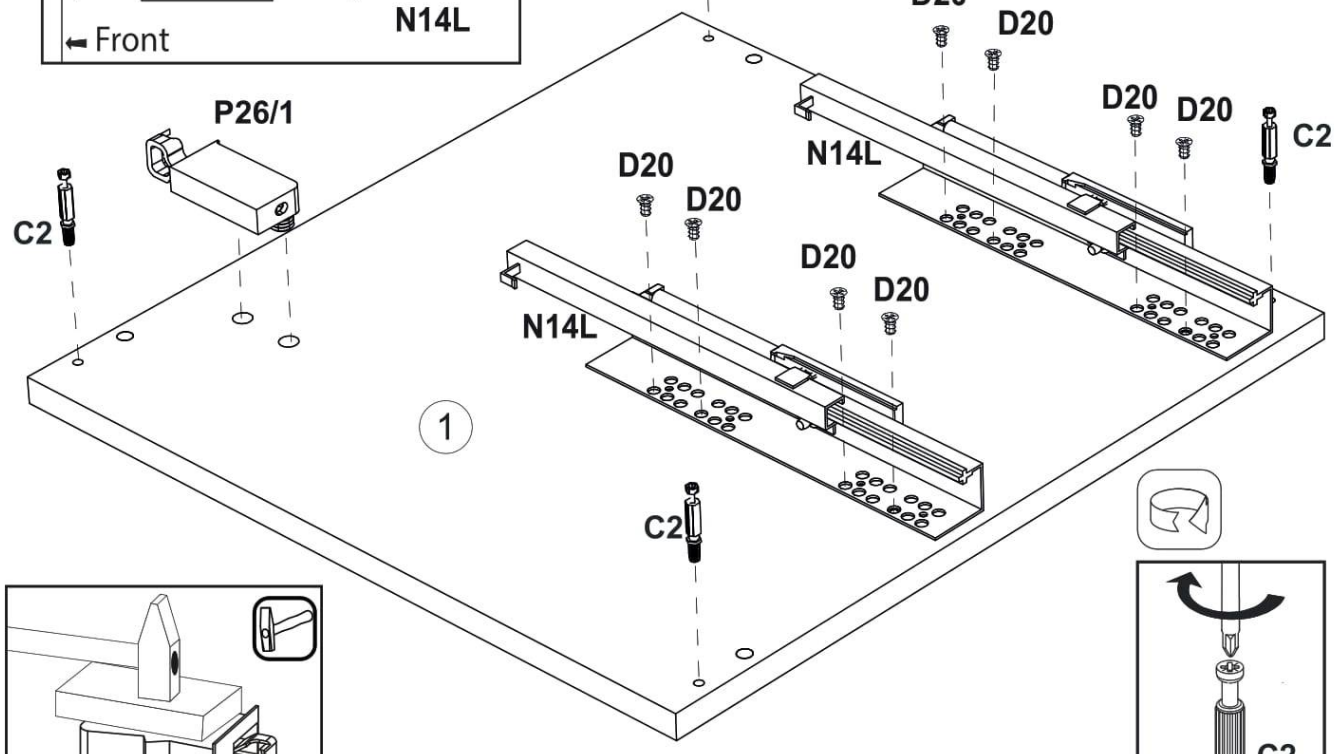
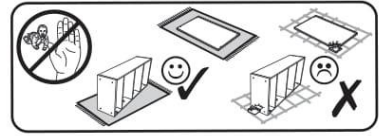
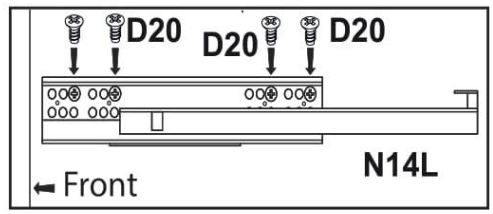

2

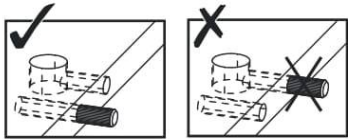
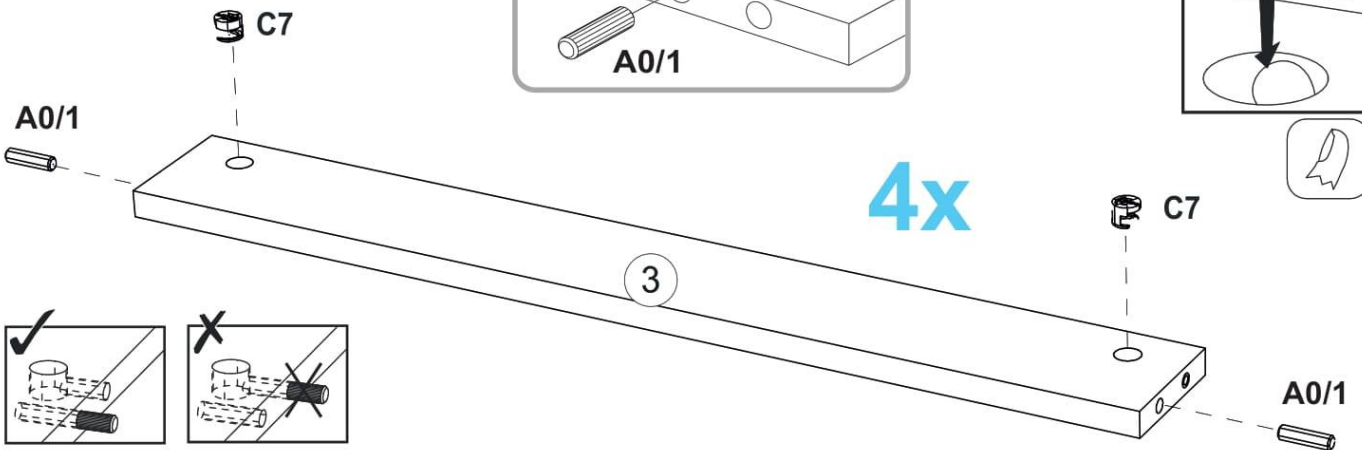
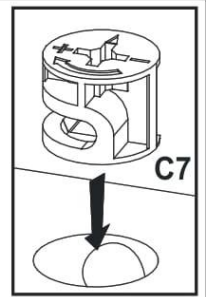
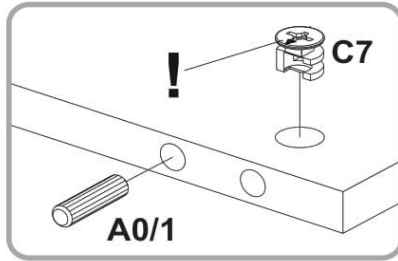
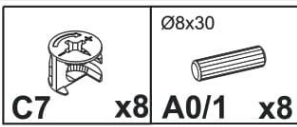

3

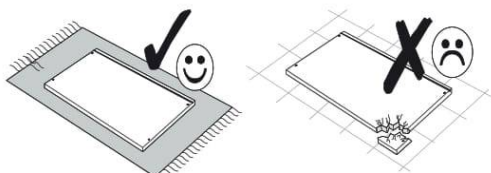
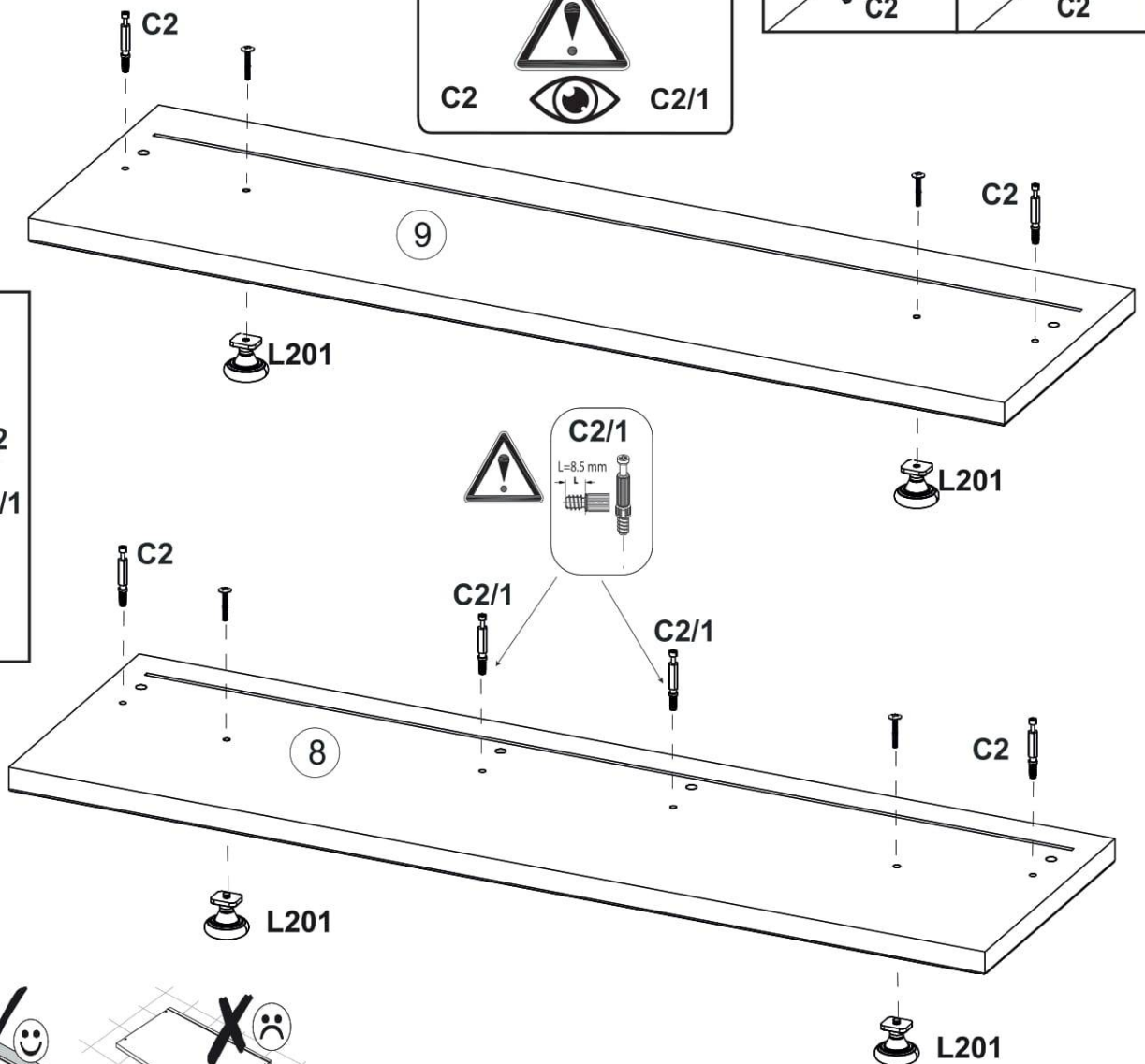
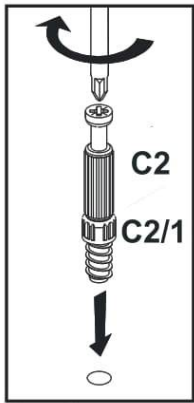
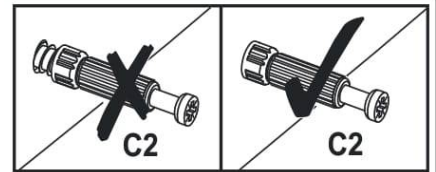

4

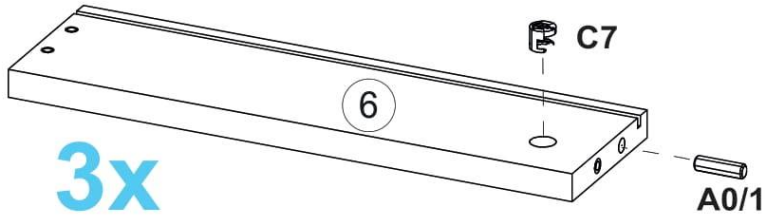
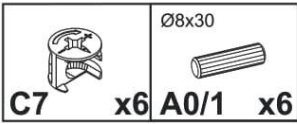

3x

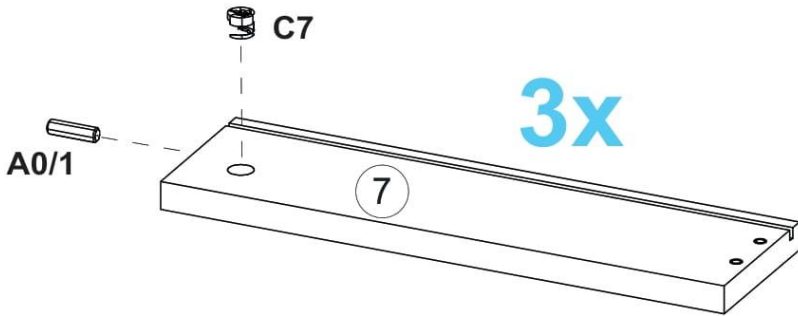
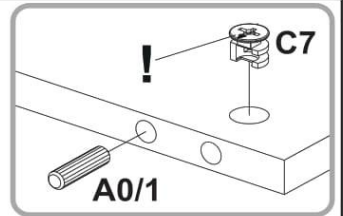
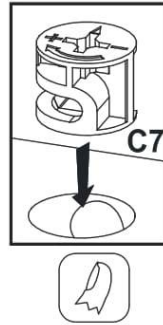

3x

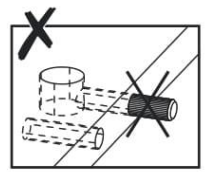
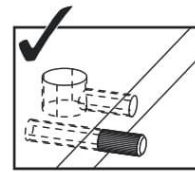

5

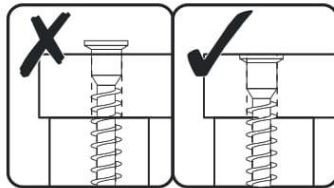
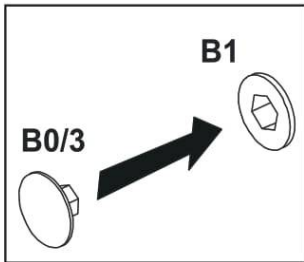
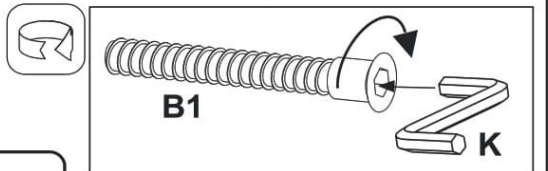
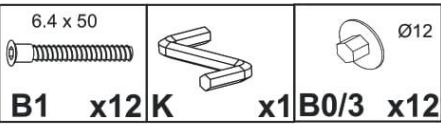



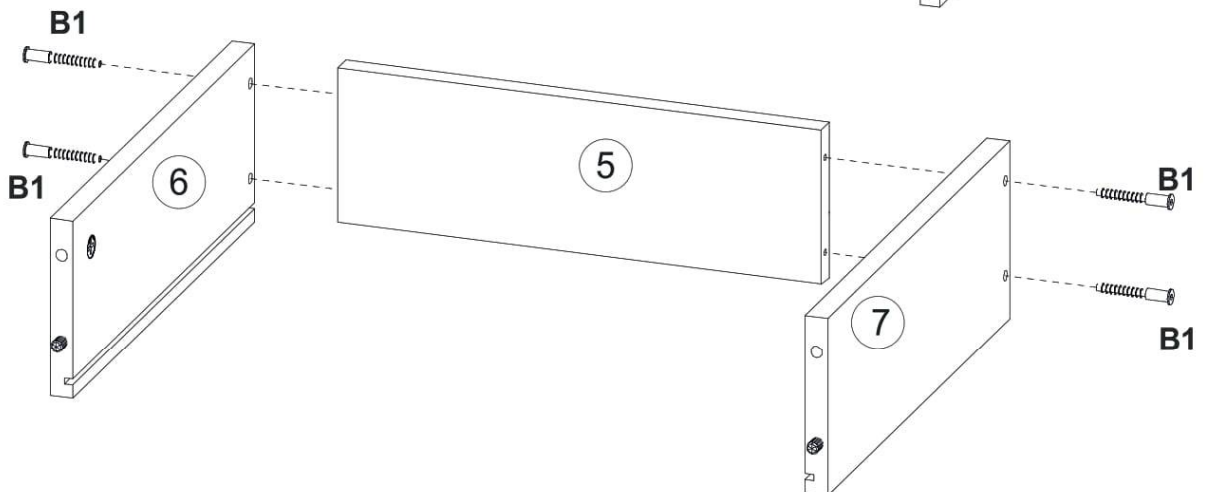
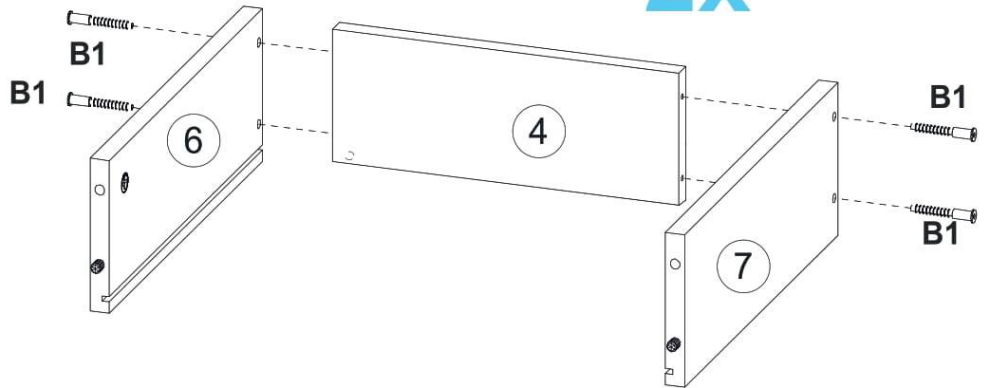

2x

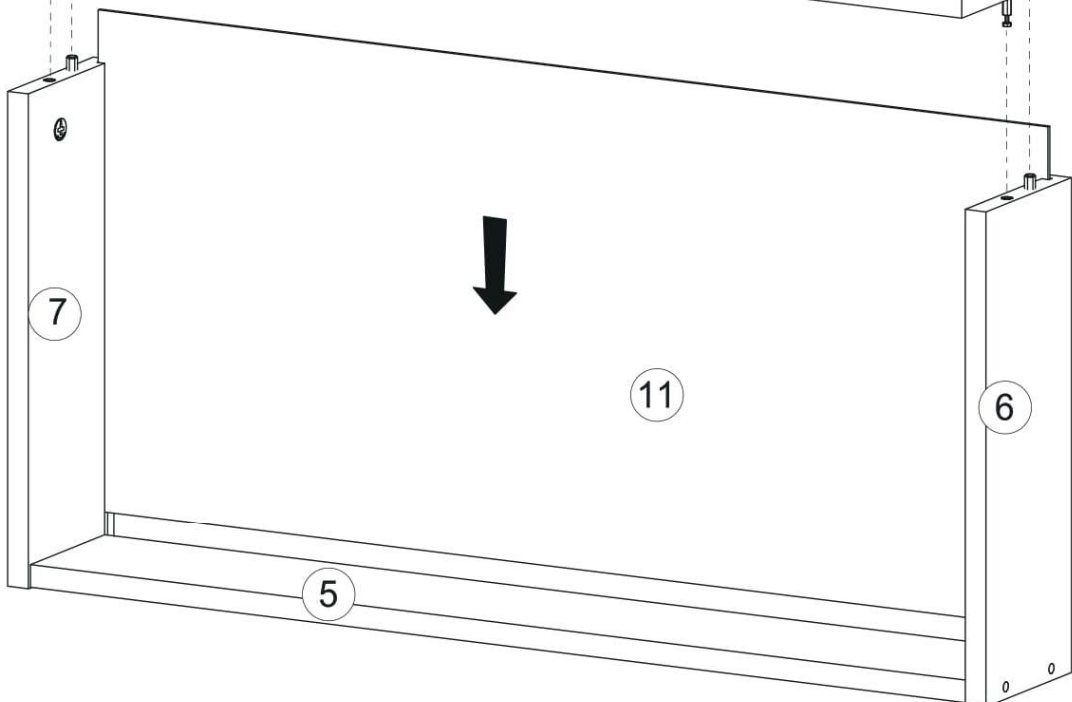
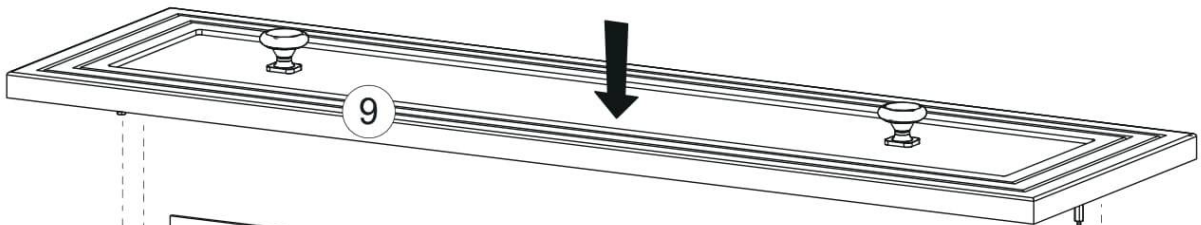
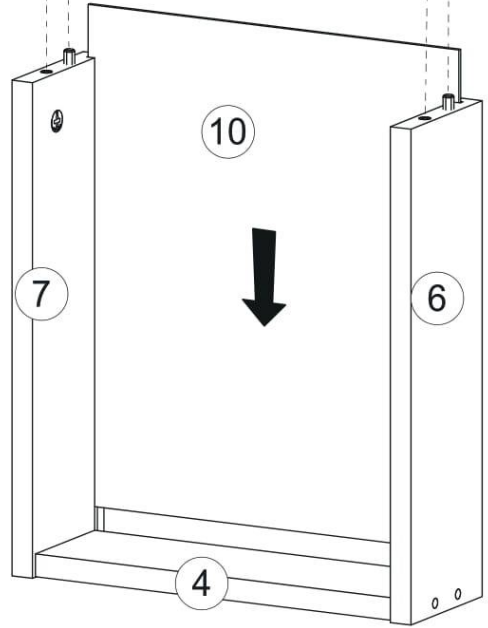
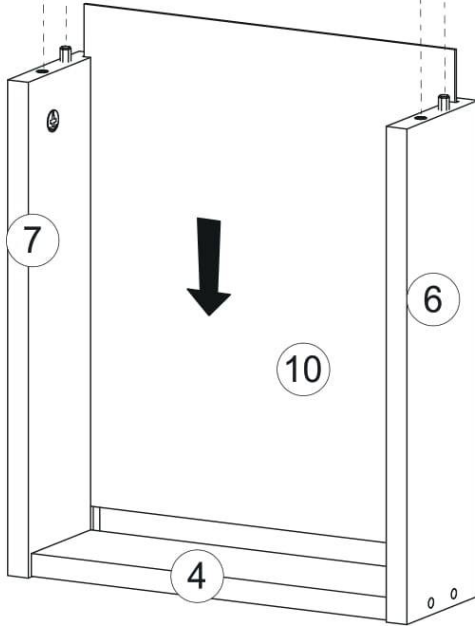
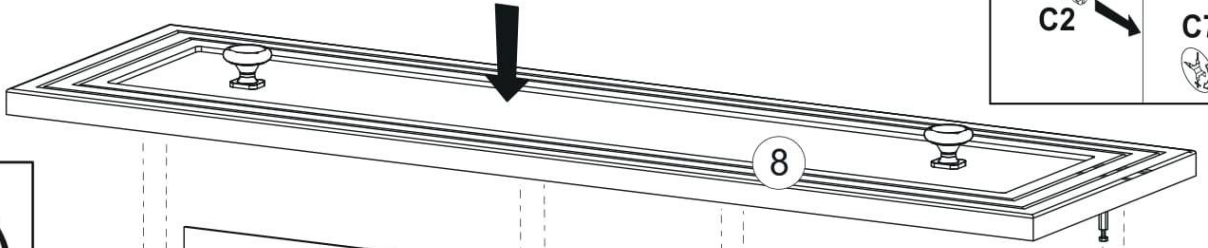
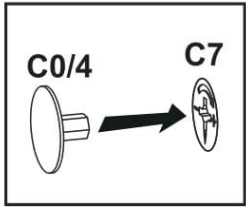
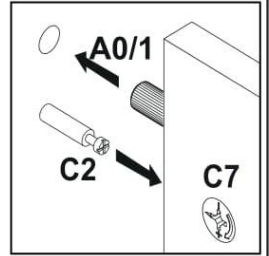
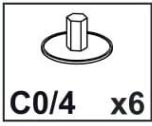

6



7

			
M1 x8	D5 x10	D36 x14	P93 x1

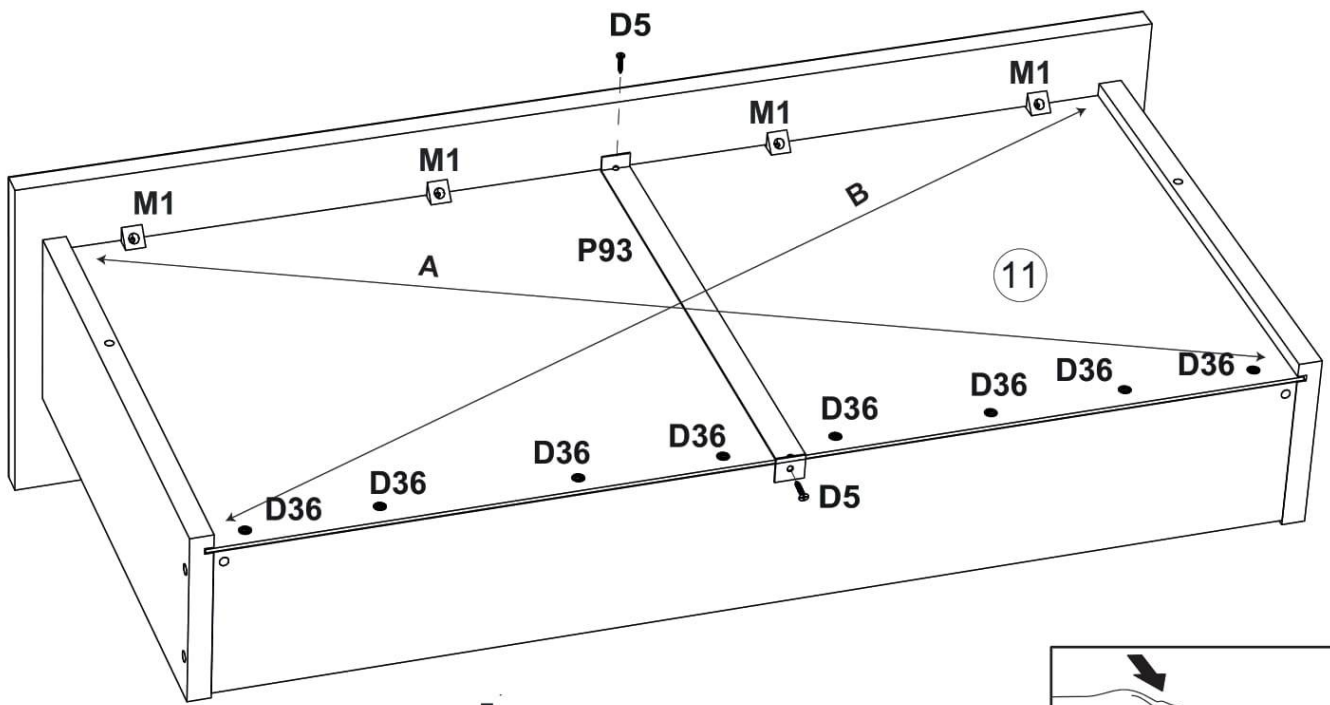
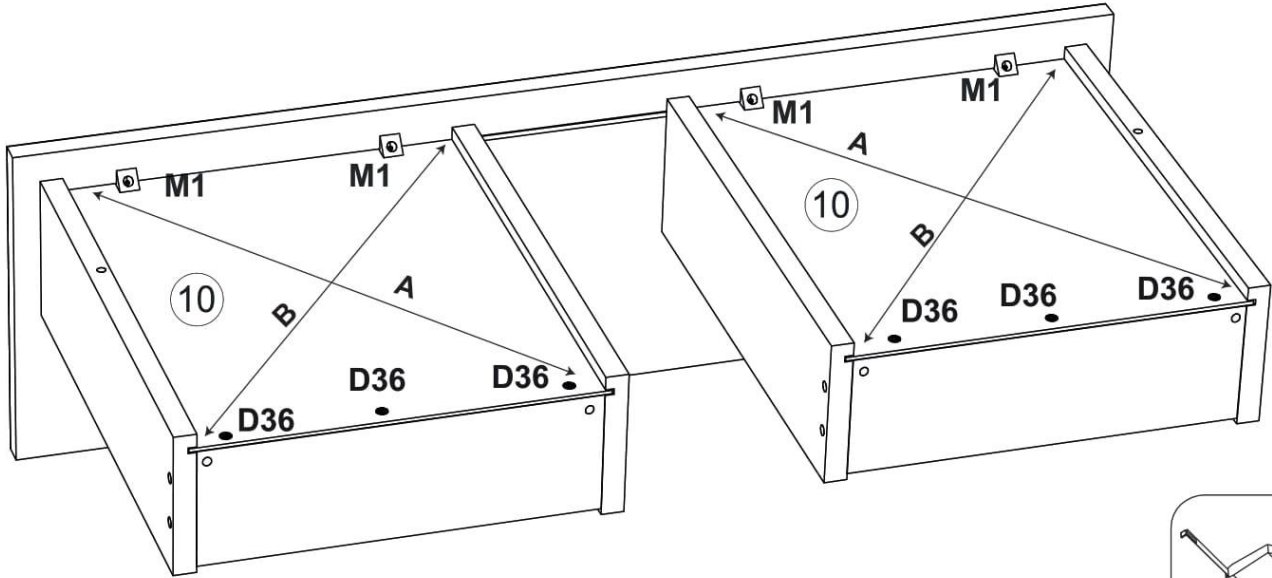
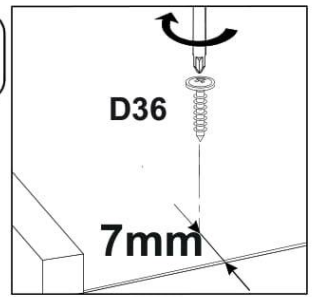
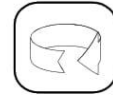

a=b

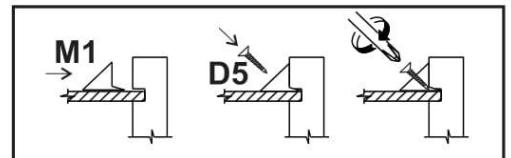
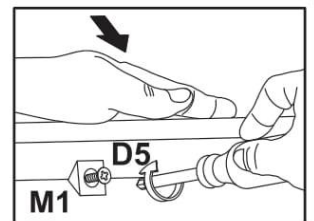
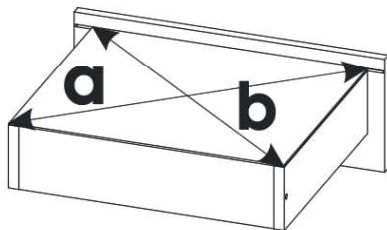

8

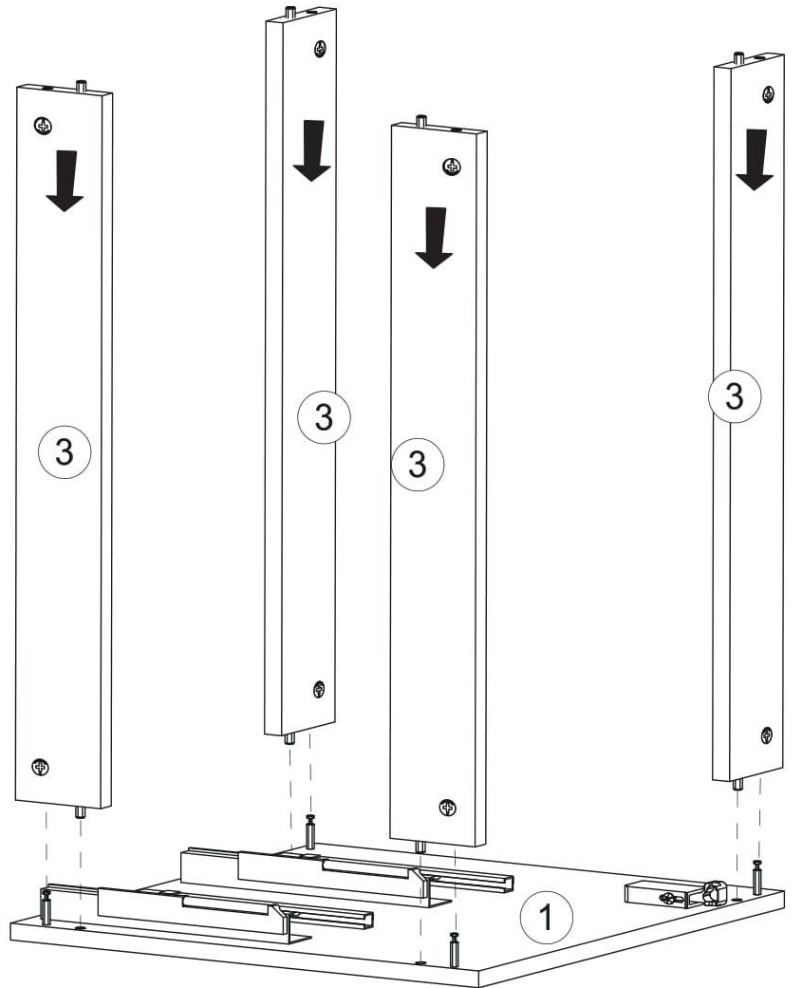
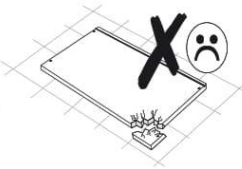
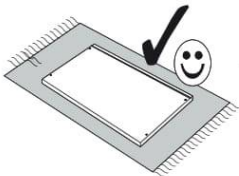
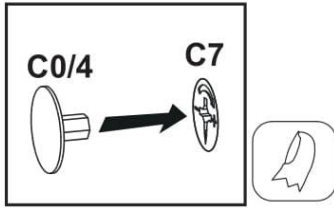
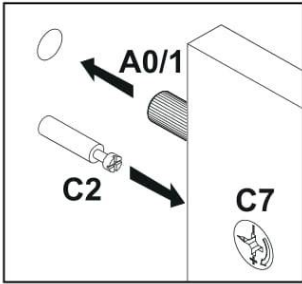
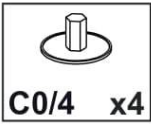

9

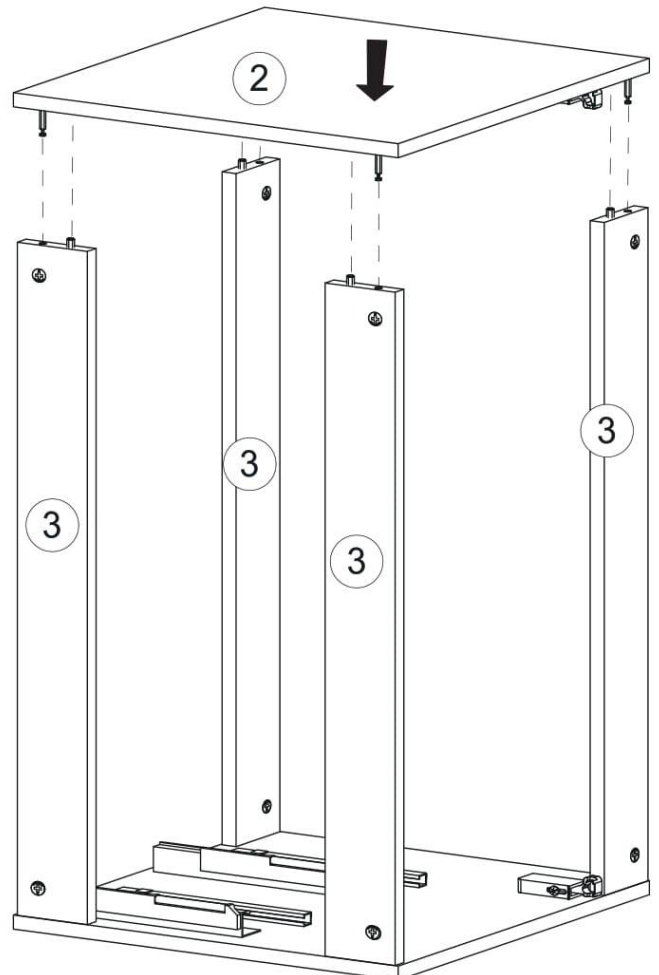
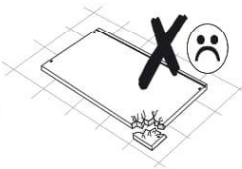
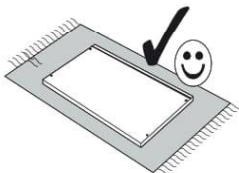
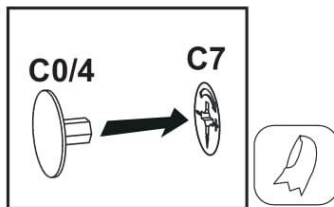
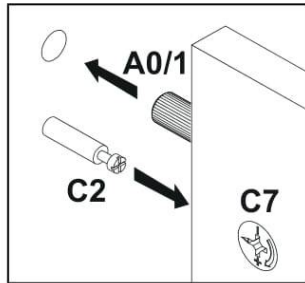
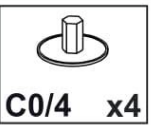

10

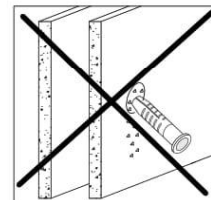
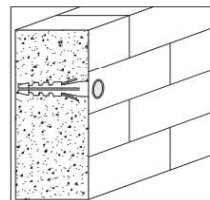
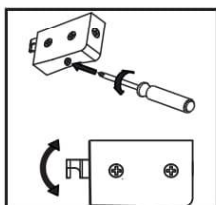
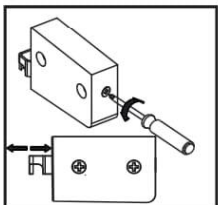
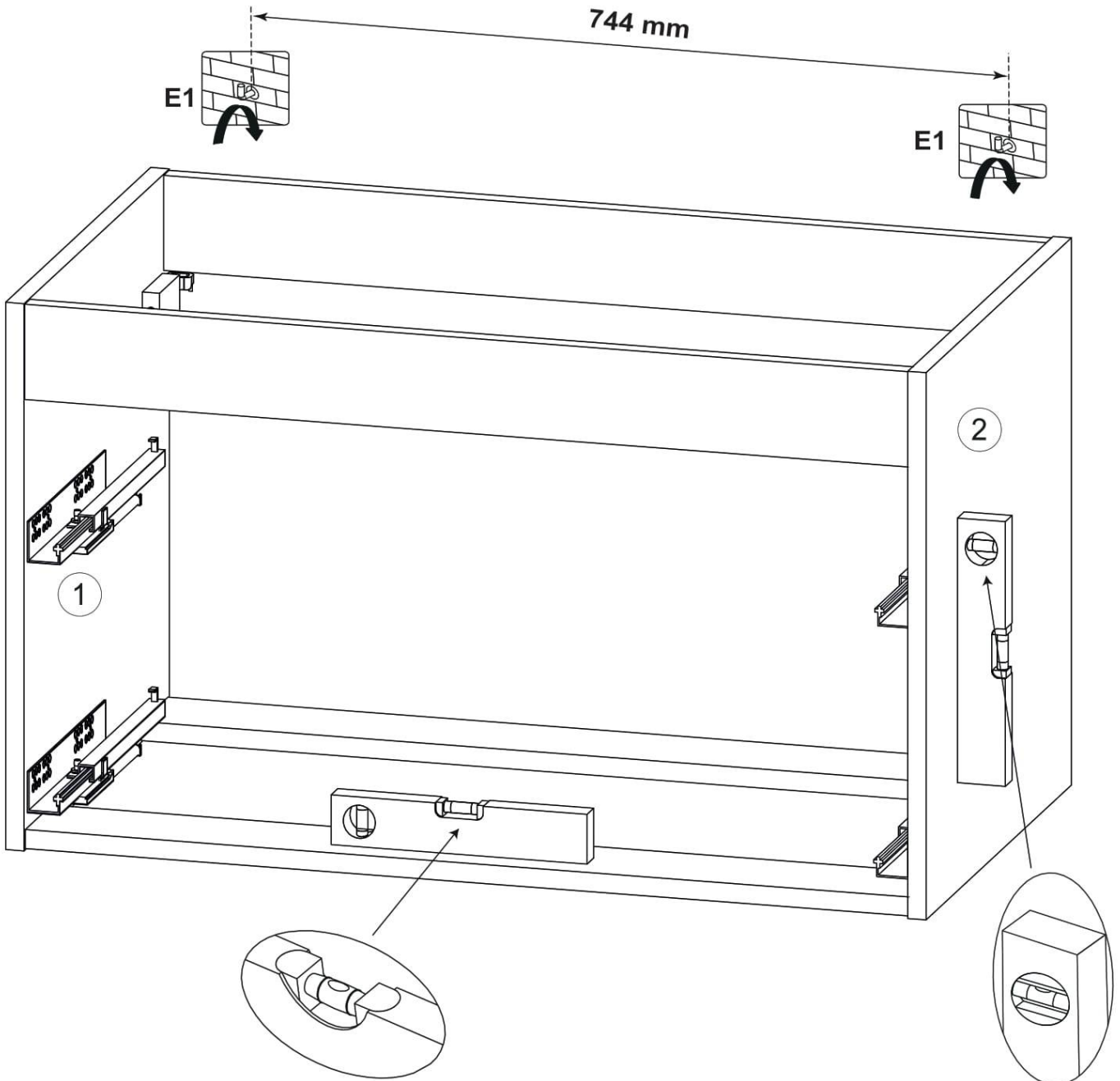
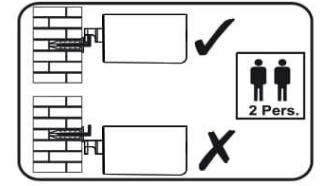
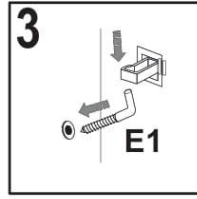
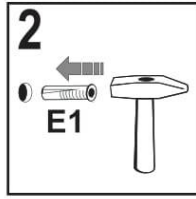
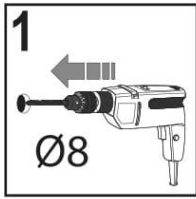
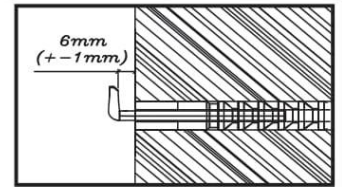
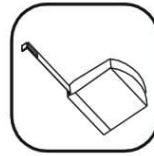
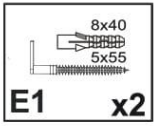

11

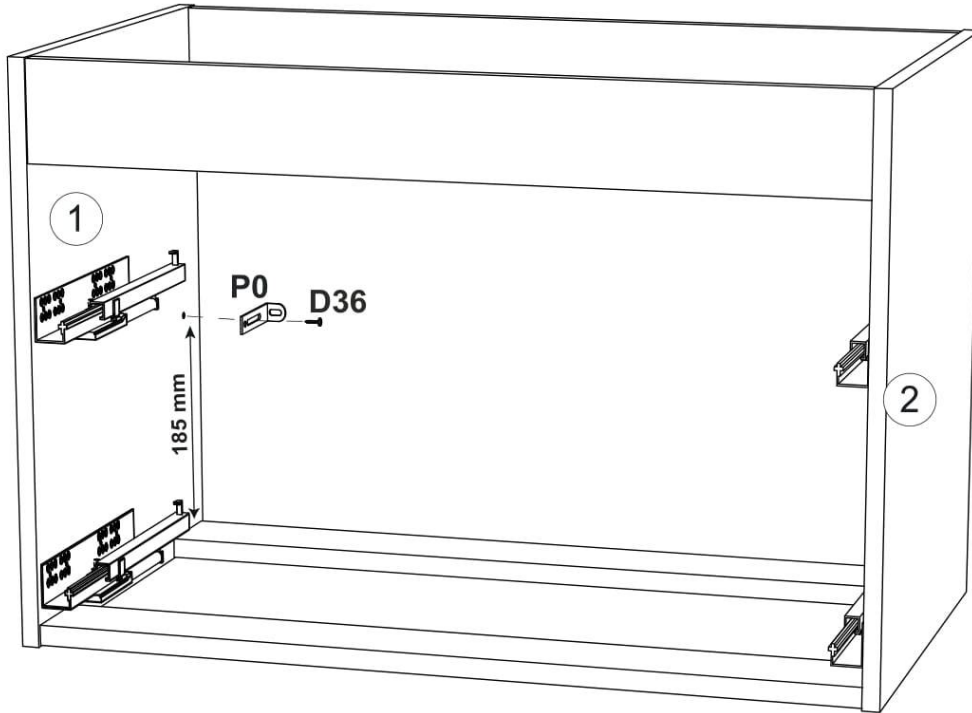
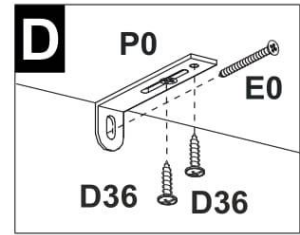
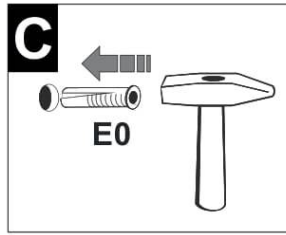
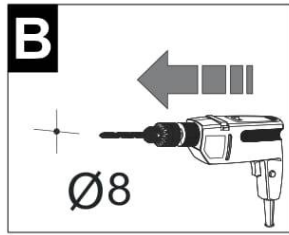
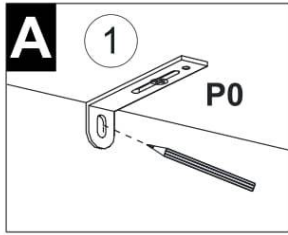
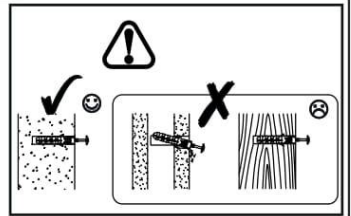

«l.»



«ll.»

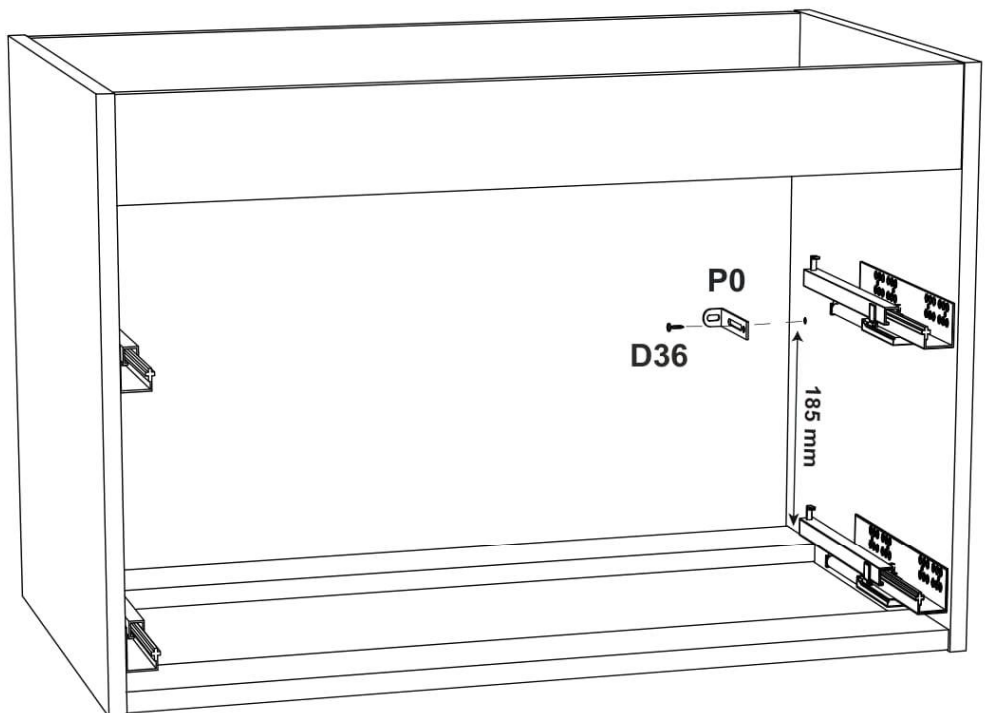
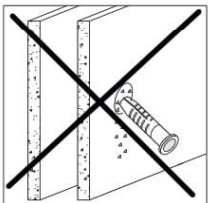
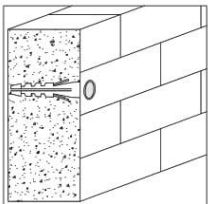

12

3,5x16
D5 x4

