

--PL-- Zapoznaj się z **INSTRUKCJĄ MONTAŻU** i postępuj zgodnie z wytycznymi opracowanymi przez producenta – w przeciwnym wypadku może wystąpić niebezpieczeństwo. --DE-- Lesen Sie die **MONTAGEANLEITUNG** und befolgen Sie die Anweisungen des Herstellers – andernfalls kann eine Gefahr entstehen. --EN-- Read the **ASSEMBLING INSTRUCTIONS** and follow the manufacturer's instructions - otherwise, a hazard may occur. --CZ-- Přečtěte si **MONTÁŽNÍ NÁVOD** a dodržujte pokyny výrobce - jinak může nastat nebezpečí. --HR-- Pročitajte **UPUTE ZA SASTAVLJANJE** i slijedite upute proizvođača - u suprotnom može doći do opasnosti. --HU-- Olvassa el az **ÖSSZESZERELÉSI ÚTMUTATÓT**, és kövesse a gyártó utasításait – ellenkező esetben veszély állhat elő. --SK-- Prečítajte si **NÁVOD NA MONTÁŽ** a postupujte podľa pokynov výrobcu - v opačnom prípade môže dôjsť k nebezpečenstvu. --FR-- Lisez les **INSTRUCTIONS D'ASSEMBLAGE** et suivez les instructions du fabricant - sinon, un danger peut survenir. --IT-- Leggere le **ISTRUZIONI DI INSTALLAZIONE** e seguire le linee guida sviluppate dal produttore - altrimenti potrebbe verificarsi un pericolo. --ES-- Lea las **INSTRUCCIONES DE MONTAJE** y siga las instrucciones del fabricante - de lo contrario podría producirse un peligro.

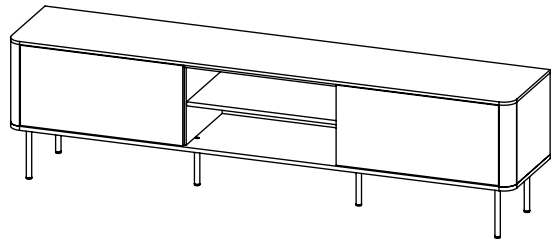

SOLANO

RTV-2

RTV 200 2D EF

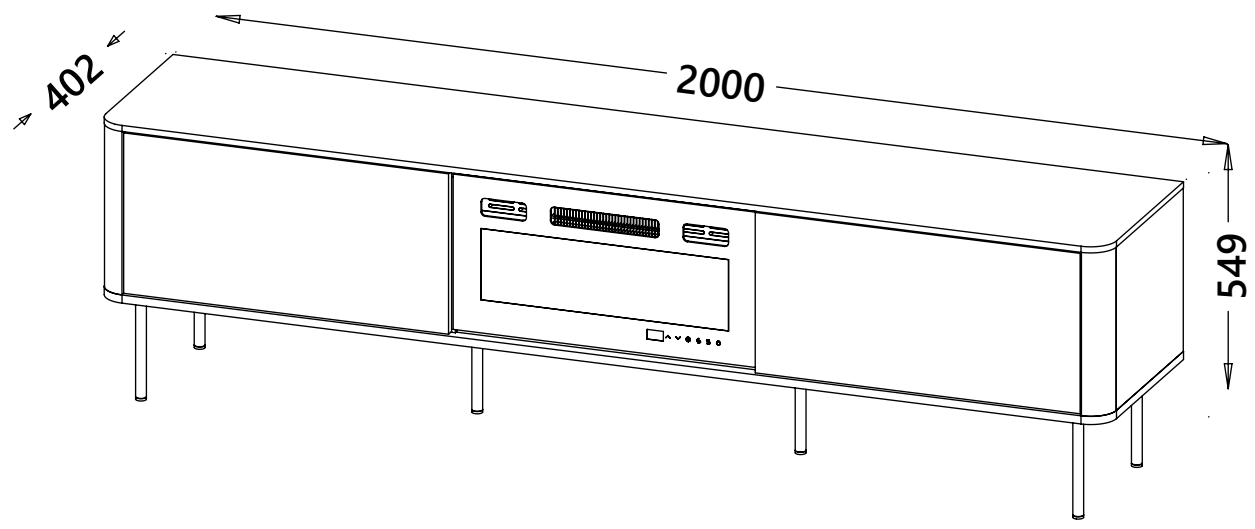

PL- Narzędzia niezbędne do montażu (nie dostarczone przez producenta)/ **DE-** Für die Montage notwendige Werkzeuge (nicht vom Hersteller mitgeliefert)/ **EN-** Tools required for assembly (not provided by the manufacturer)/ **CZ-** Nástroje nezbytné pro montáž (nejsou dodávány výrobcem)/ **HR-** Alat potreban za montažu (nije osiguran od strane proizvođača)/ **HU-** Az összeszereléshez szükséges (a gyártó által nem szállított) szerszámok/ **SK-** Nástroje potrebné na montáž (nedodávané výrobcem)/ **FR-** Outils requis pour l'assemblage (non fournis par le fabricant)/ **ES-** Herramientas necesarias para el montaje (no proporcionadas por el fabricante)/ **IT-** Strumenti necessari per il montaggio (non forniti dal produttore)

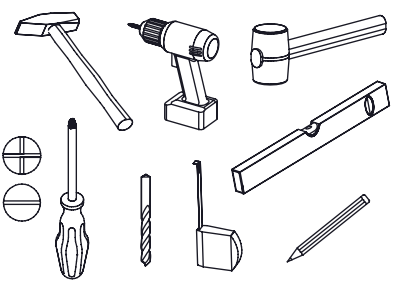

HALMAR Sp. z o.o.
UL. COP 2
37-450 Stalowa Wola, Polska
info@halmar.pl



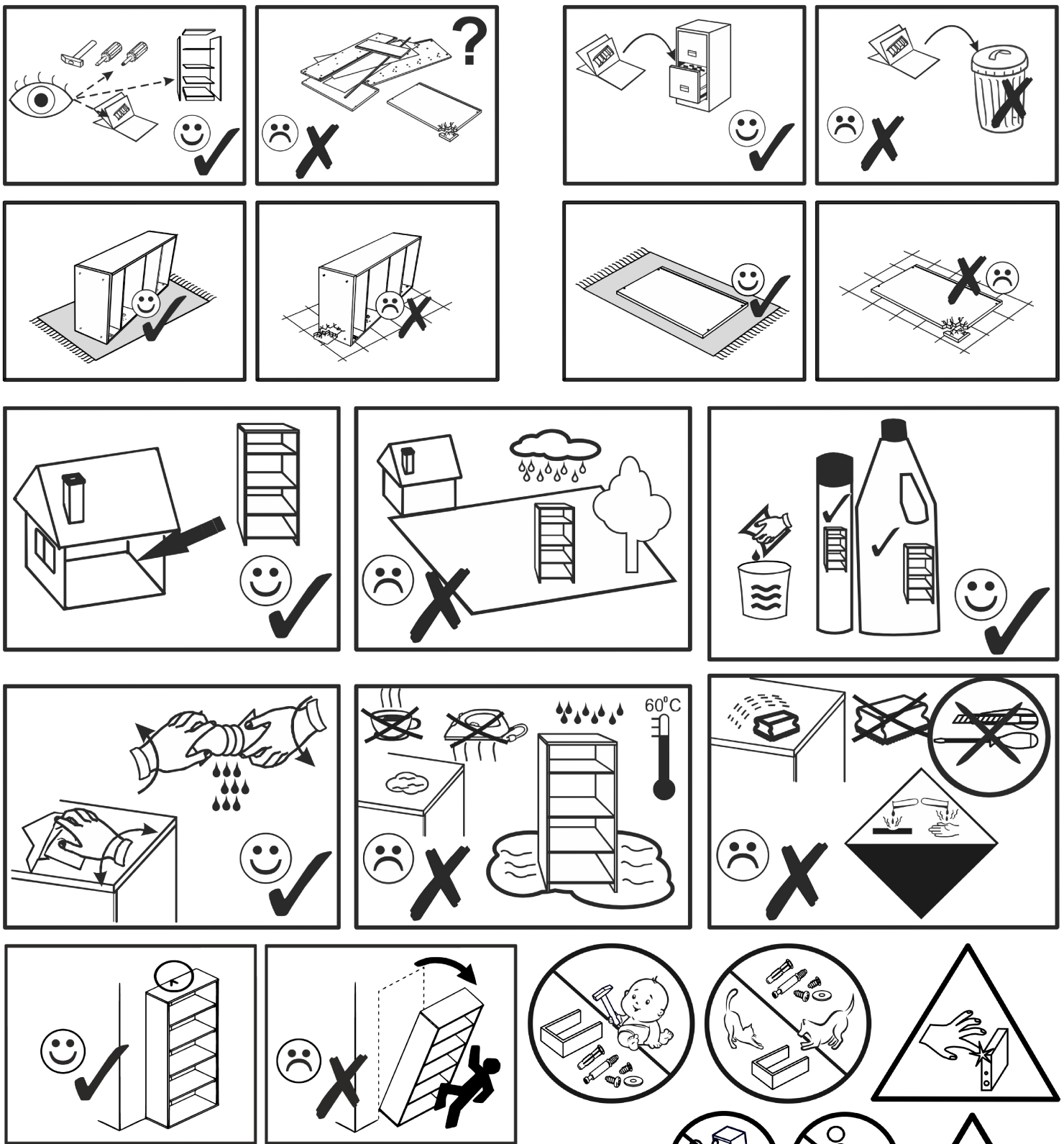

PL -Szanowny Kliencie, jeśli zamontujesz uszkodzony element, Twoja reklamacja nie będzie uznana. Zachowaj etykietę do celów reklamacyjnych. --- **DE** -Sehr geehrter Kunde, wenn Sie ein defektes Bauteil einbauen, wird Ihre Reklamation nicht anerkannt. Bewahren Sie das Etikett für Reklamationszwecke auf. --- **EN** -Dear Customer, if you install a defective component, your claim will not be accepted. Keep the label for claim purposes. --- **CZ** -Vážený Zákazníku, pokud nainstalujete vadný komponent, vaše reklamace nebude uznána. Štítek si uschovejte pro účely reklamace. --- **SK** -Vážený Zákazník, ak nainštalujete chybný komponent, vaša reklamácia nebude uznaná. Štítk si uschovajte na účely reklamácie. --- **HR** -Poštovani Kupci, ukoliko ugradite oštećeni element, reklamacija se neće uvažiti. Sačuvajte naljepnicu u svrhu reklamacije. --- **HU** -Kedves Vásárló, ha hibás alkatrészt szerel be, panaszát nem ismerjük el. Tartsa meg a címkét az igényléshez. --- **FR** -Cher Client, si vous installez un composant défectueux, votre réclamation ne sera pas prise en compte. Conserver l'étiquette en cas de réclamation. --- **ES** -Estimado cliente, si instala un componente defectuoso, no se aceptará su reclamo. Conserve la etiqueta para realizar el reclamo. --- **IT** -Gentile Cliente, se installi un elemento danneggiato il tuo reclamo non verrà accettato verrà riconosciuto. Conservare l'etichetta per eventuali reclami.

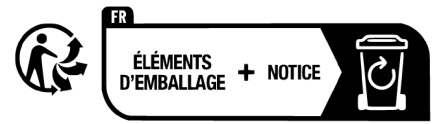
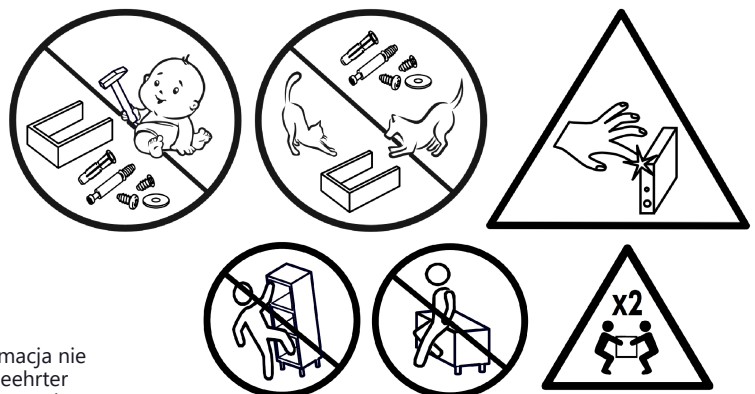

A

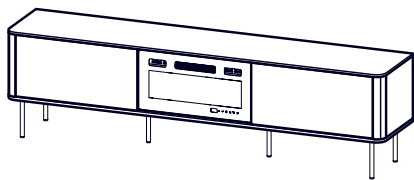

B

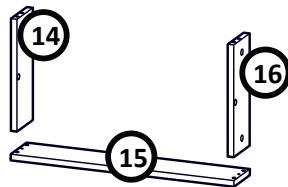
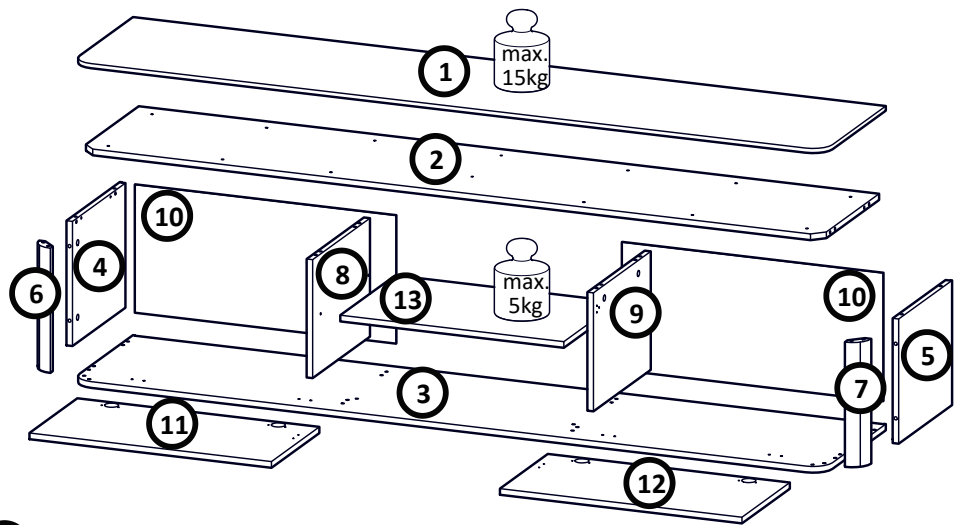
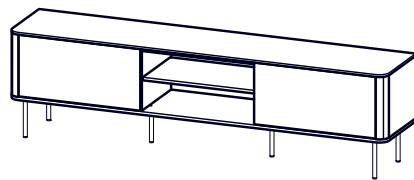

Nr	Xmm	Ymm	Zmm	x
1	2000	402	12	1
2	1967	377	16	1
3	2000	402	16	1
4	321	351	16	1
5	321	351	16	1
6	321	50	50	1
7	321	50	50	1
8	305	377	16	1
9	305	377	16	1

Nr	Xmm	Ymm	Zmm	x
10	694	330	2,5	2
11	315	643	16	1
12	315	643	16	1
13	594	362	16	1
14	289	105	16	1
15	593	105	16	1
16	289	105	16	1

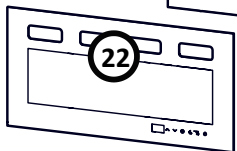
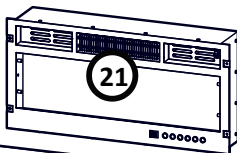

Nr	Xmm	Ymm	Zmm	x
21	592	282	110	1
22	600	304	4,5	1

A1 8x Ø7x50 	B1 20x Ø8x35 	B8 4x Ø8x30 	I20 12x Ø4/Ø17 	K5 16x 34mm 	K1 16x Ø15x12
B2 8x Ø7,8x35 	B3 2x Ø8x50 	W4 48x 	W2 1x 4mm 	G34 12x 3,5x16 	L21 2x
G4 24x 4x16 	P66 6x h200 	L10 2x 	G47 4x Ø3,5x13 	G13 14x Ø4x25 	M33 2x 37x37x3
F2 5x Ø5 	D4 4x PZ350D 	C4 4x Z350D 	G49 4x 3,5x25 	N1 2x M4x9 	I18 2x Ø14

I

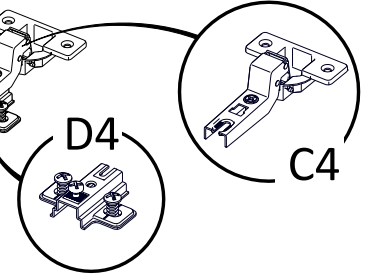
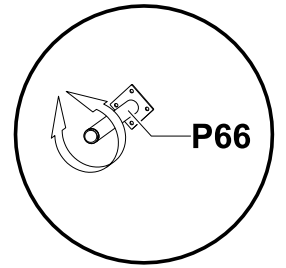
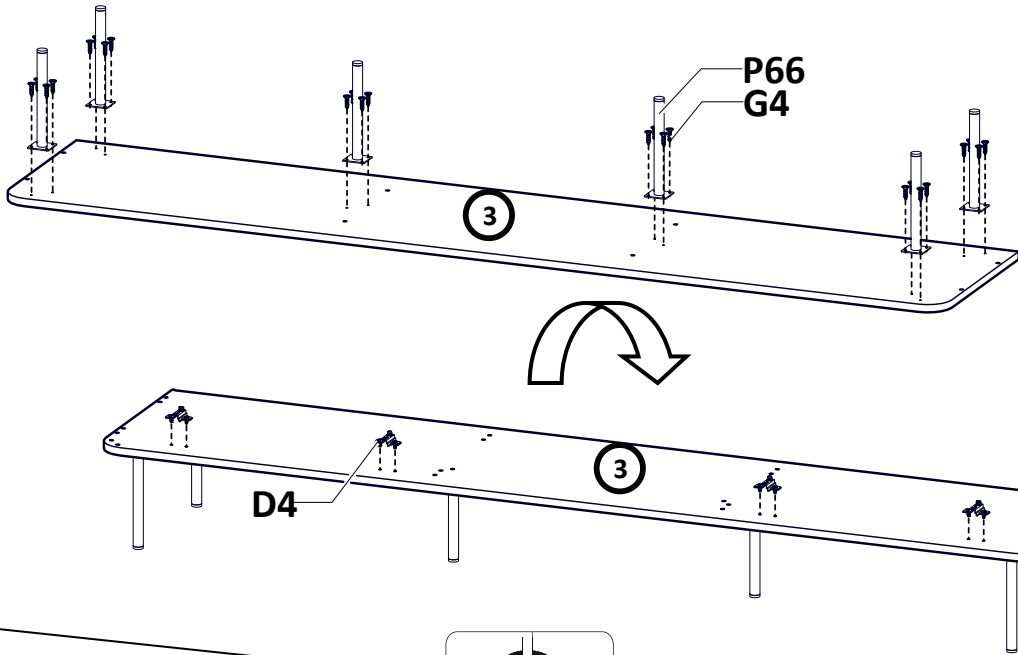

II

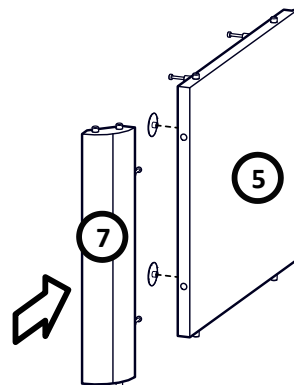
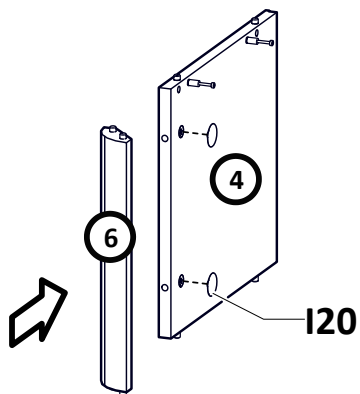
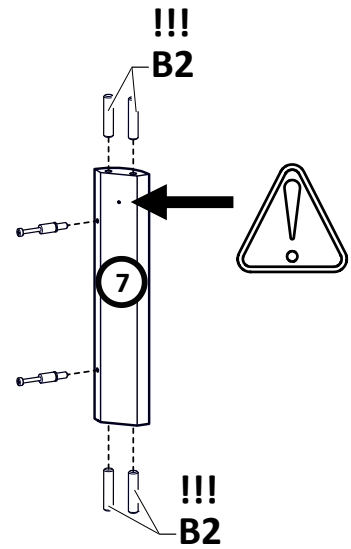
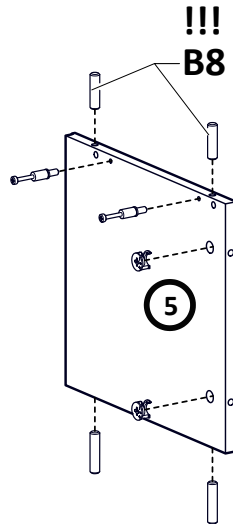
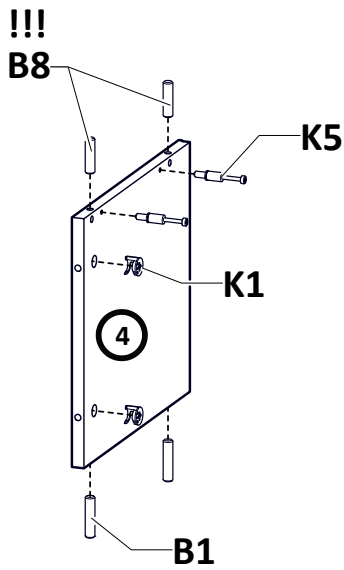
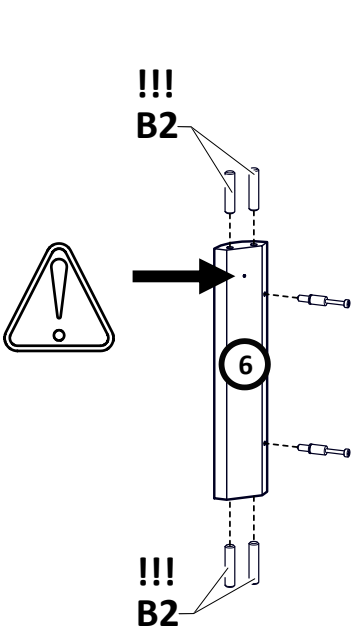
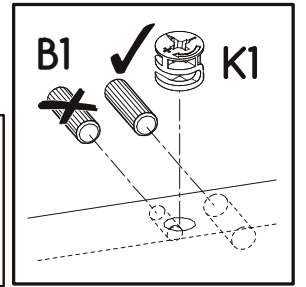
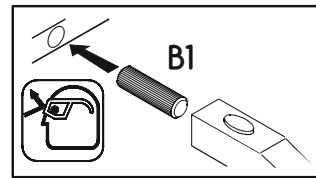
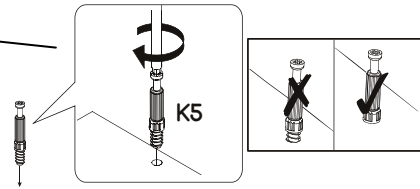

i

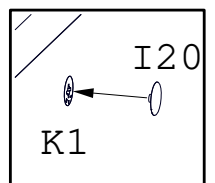
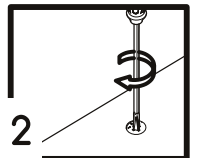
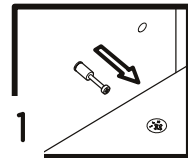

III

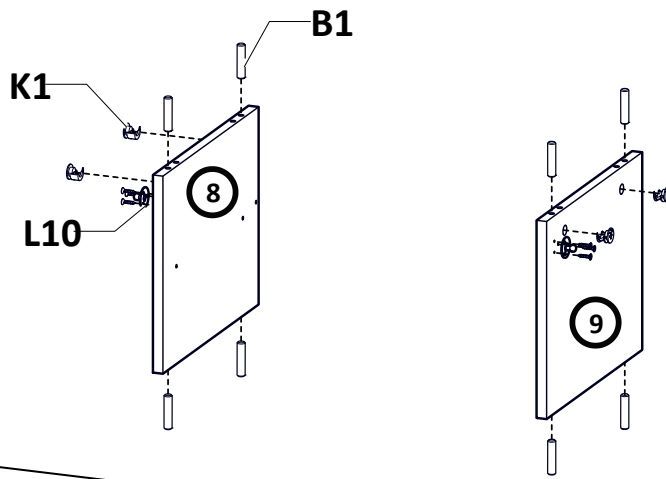

IV

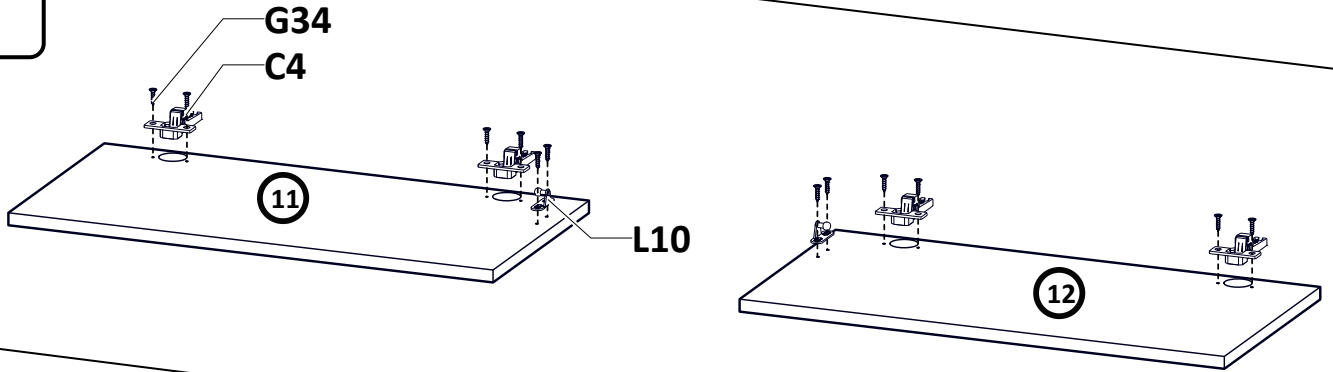

V

A

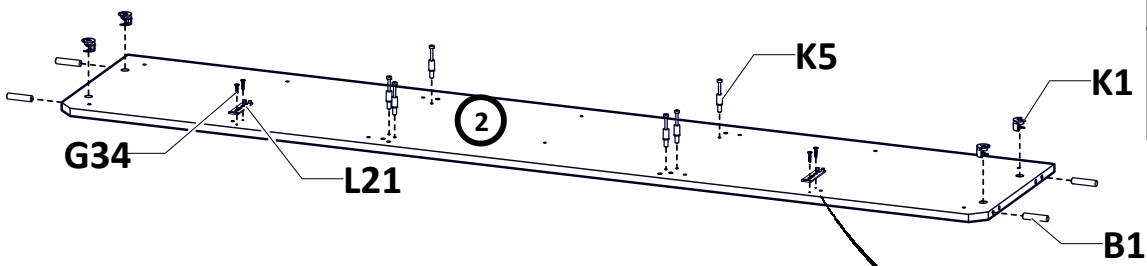
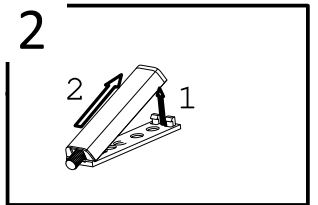
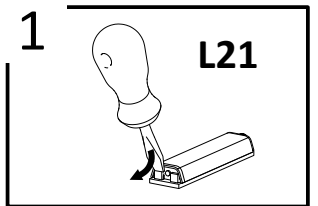
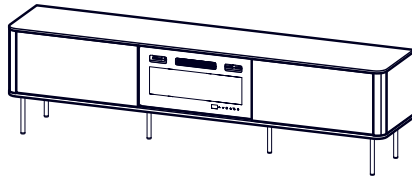

VI

A

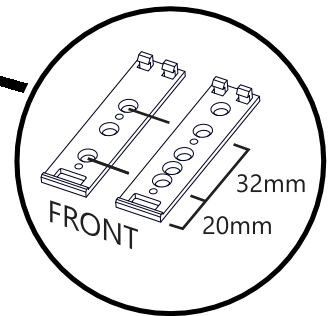
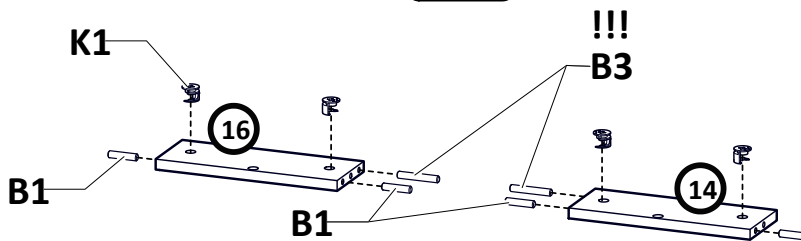

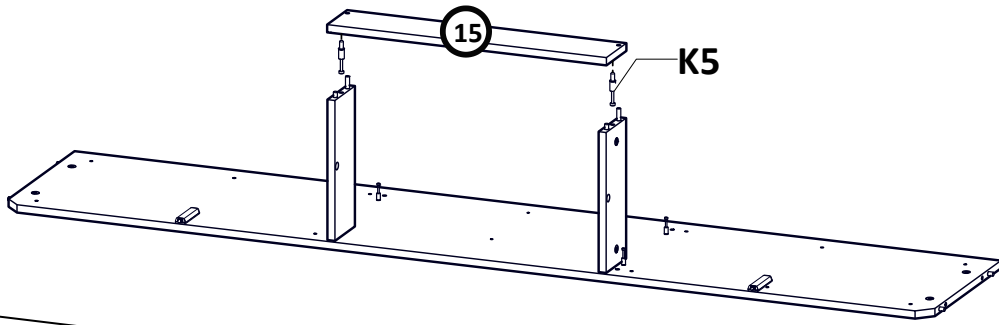
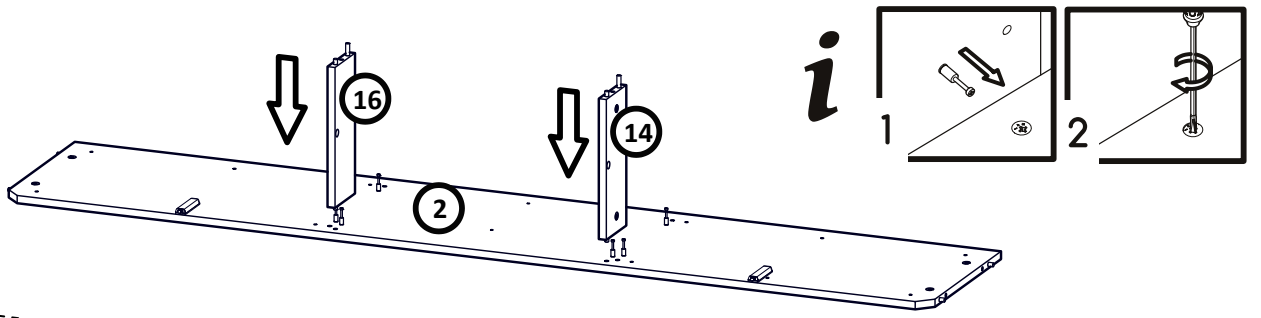

VII

A

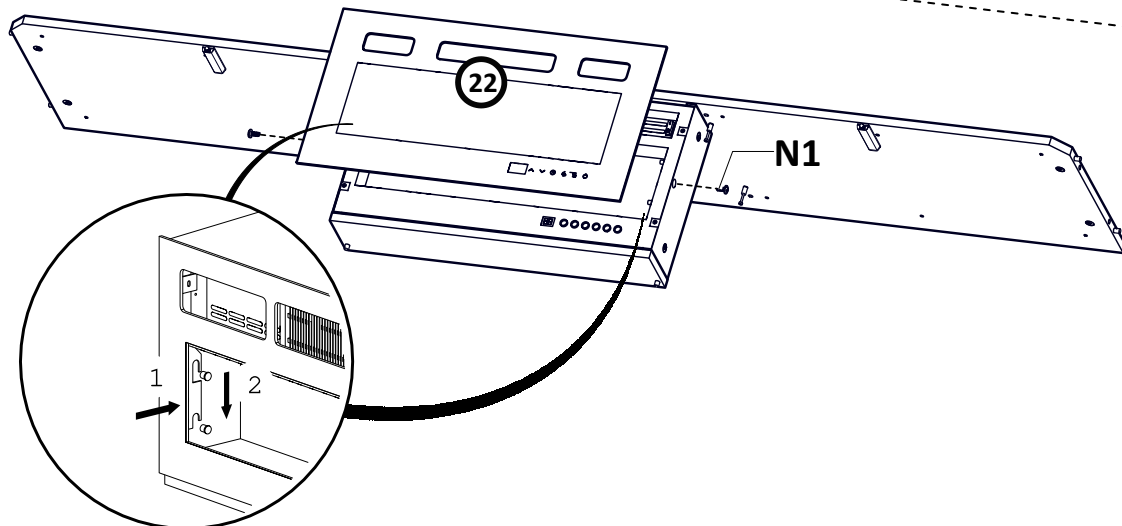
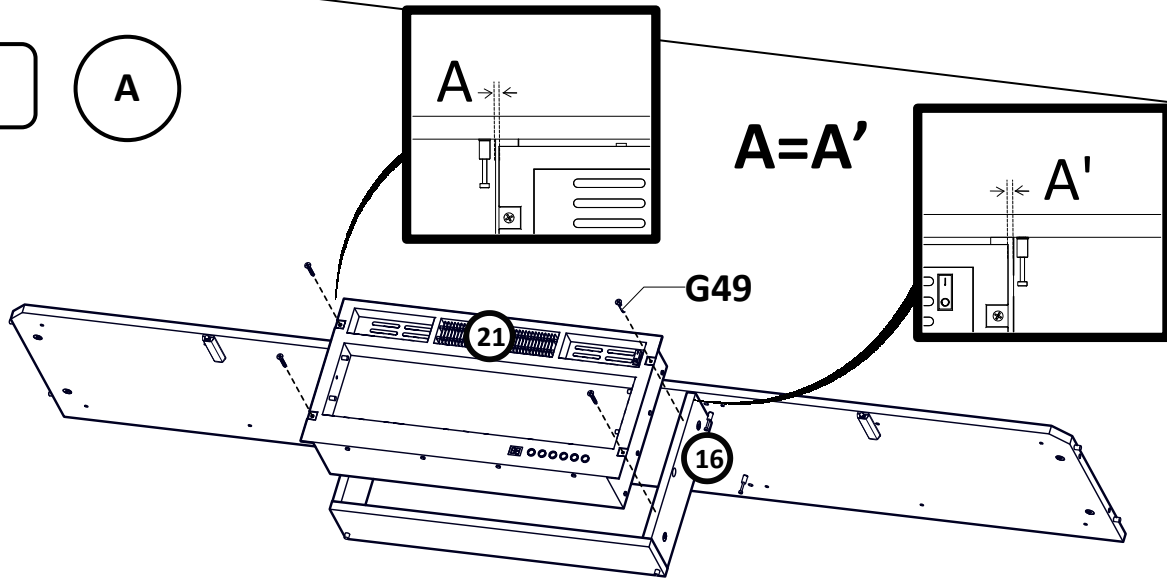

VIII

A

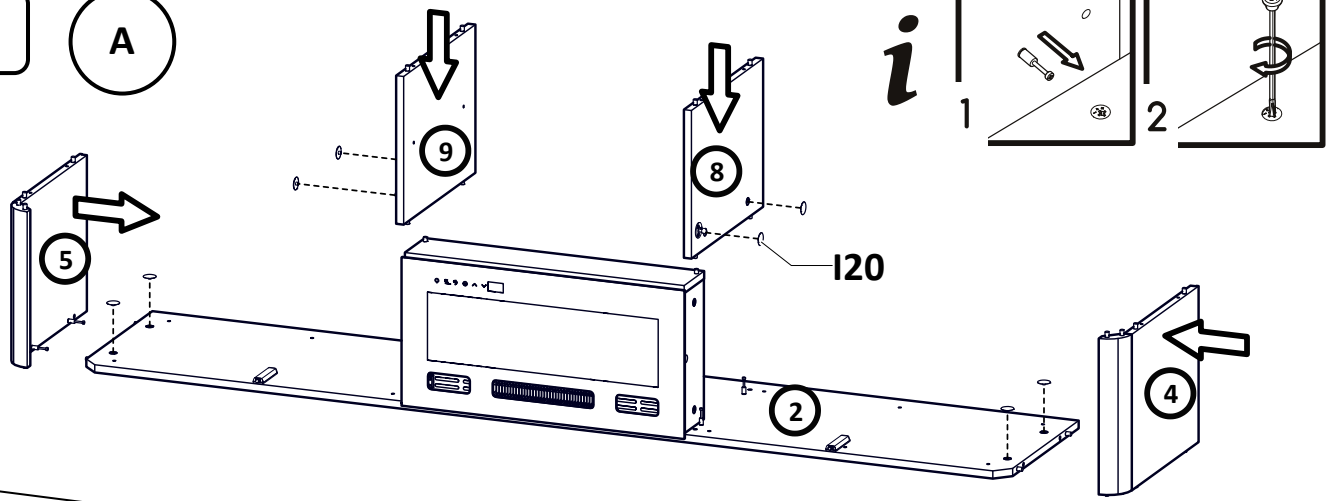

i

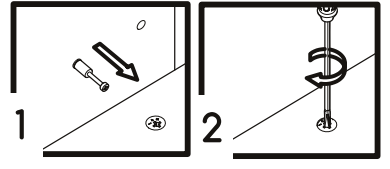

IX

A

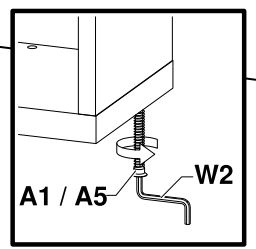
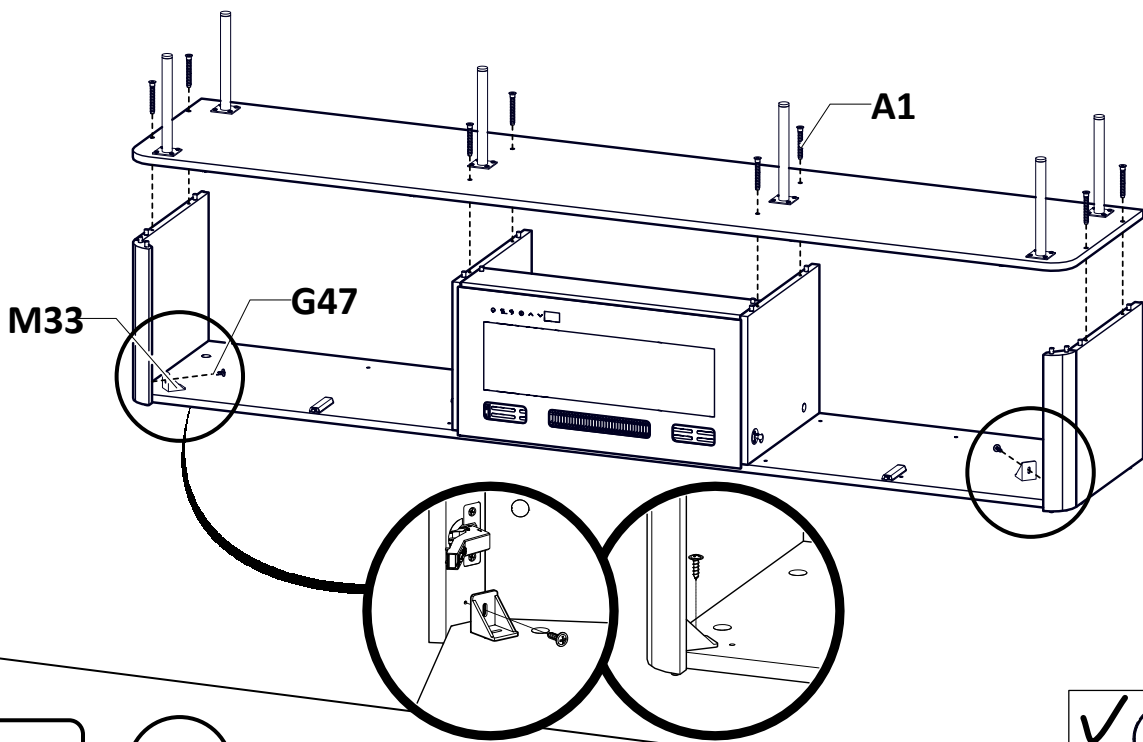

X

A

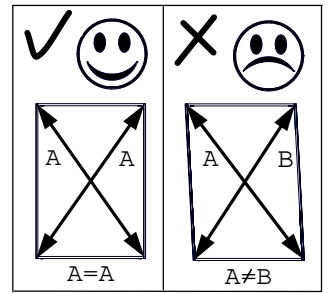
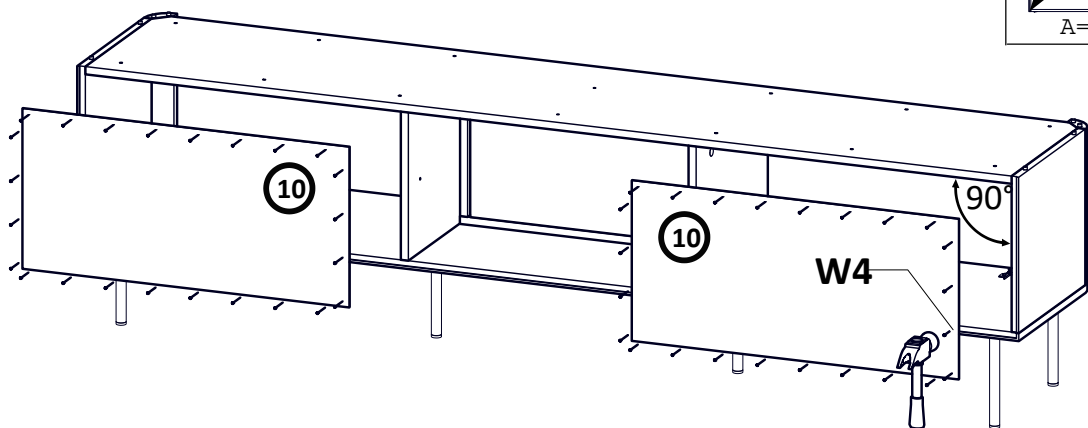

XI

A

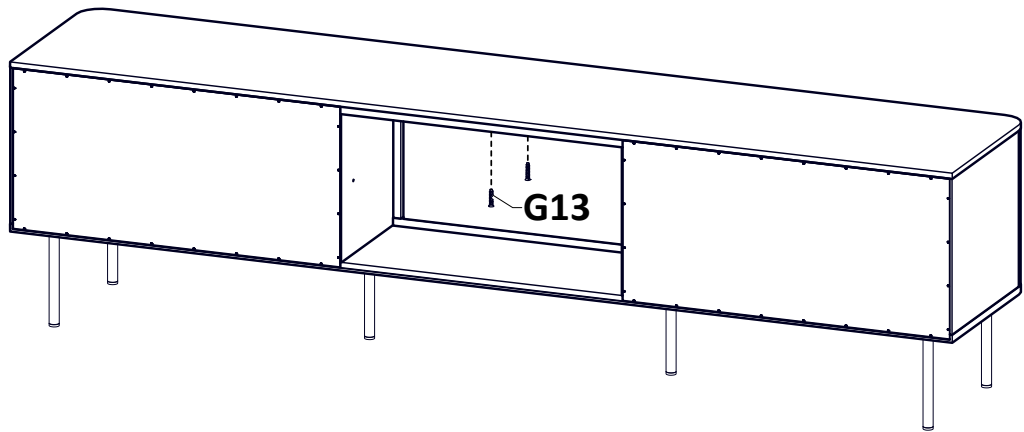
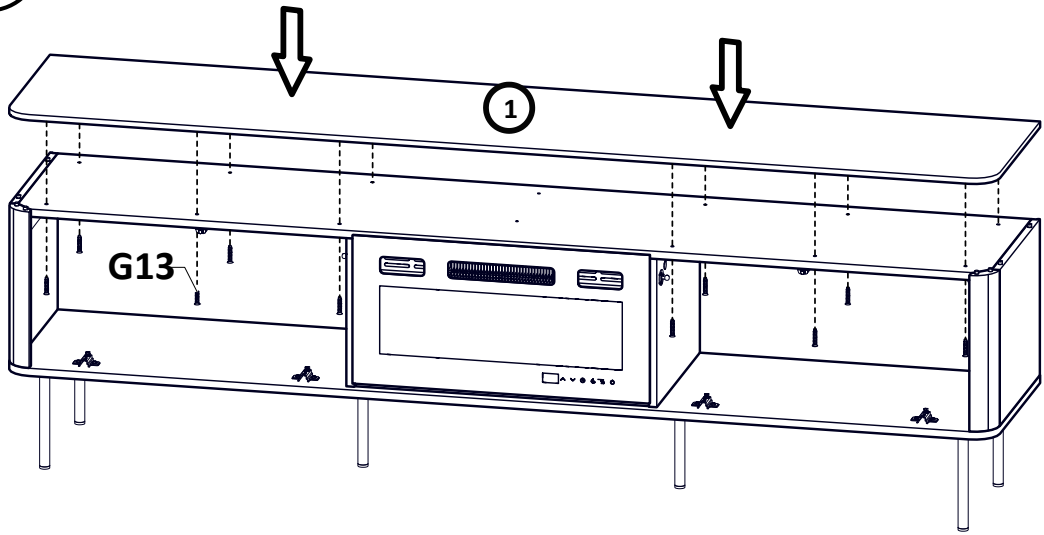

XII

A

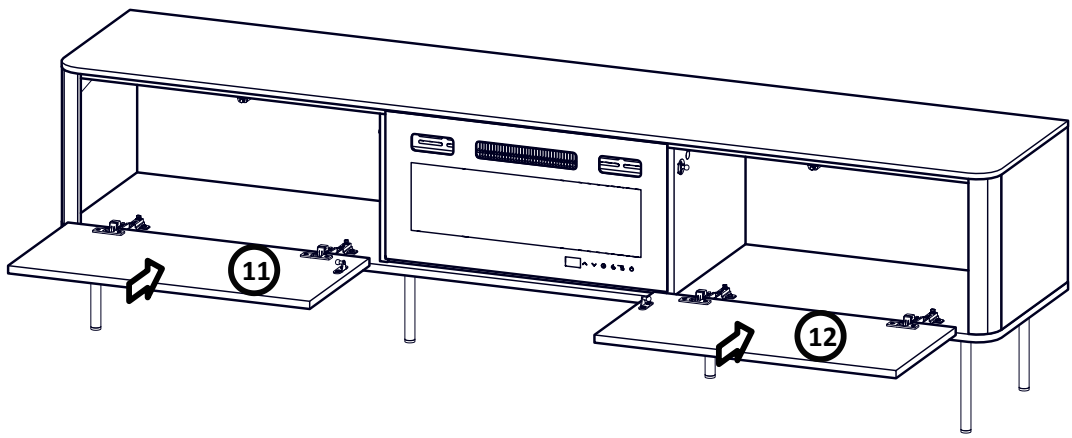

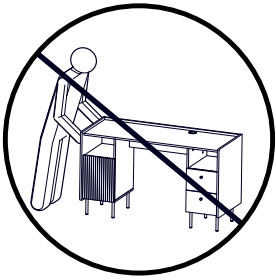
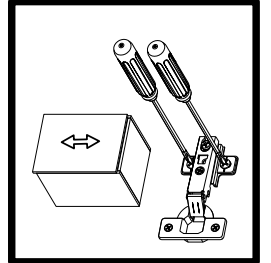
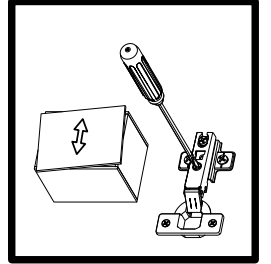
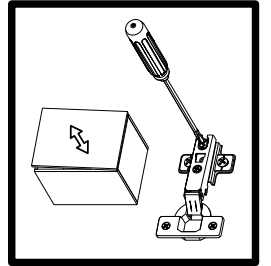
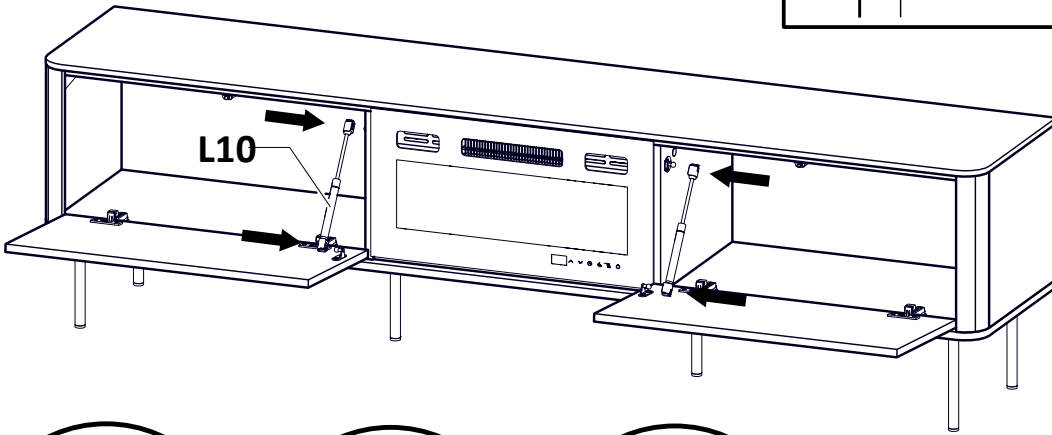
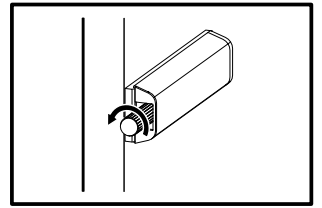
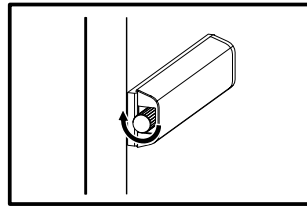

V

B

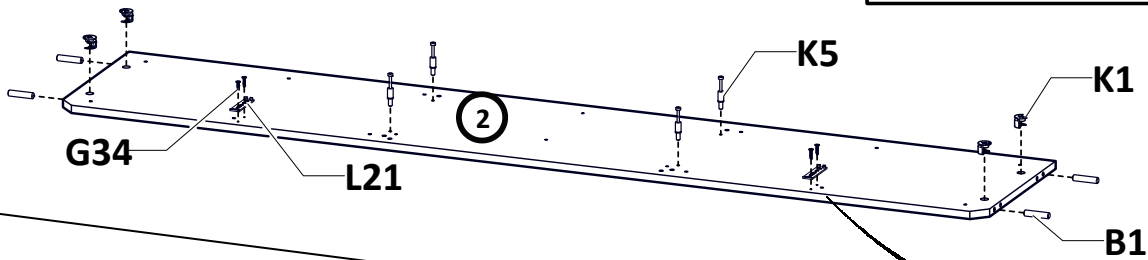
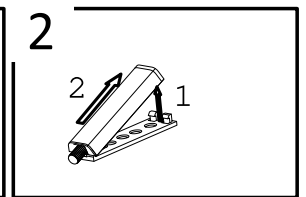
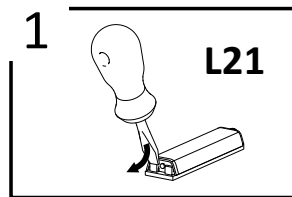
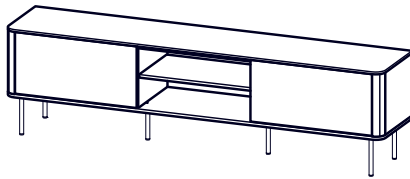

VI

B

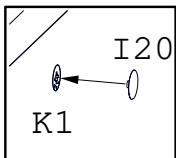
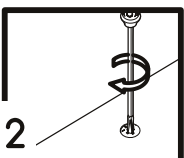
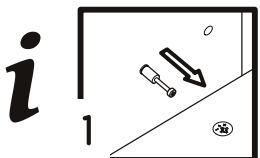
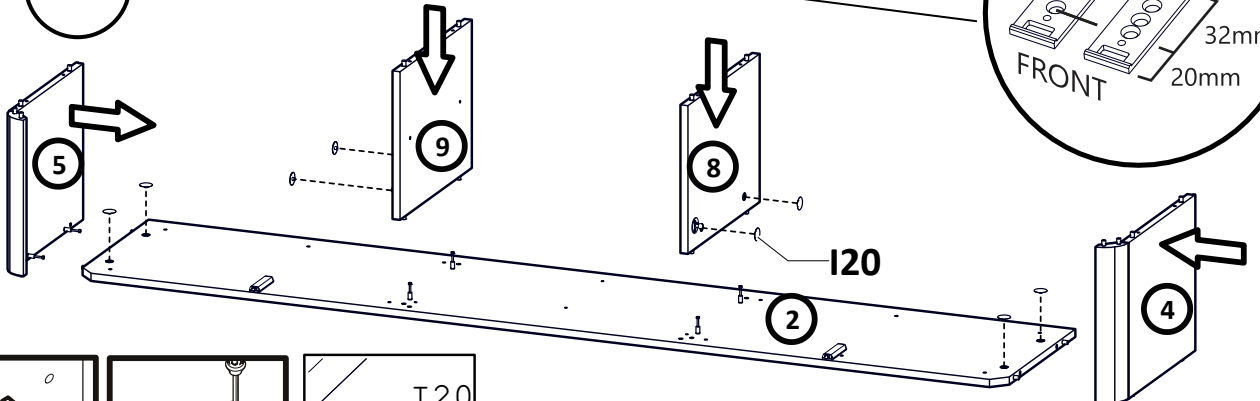

VII

B

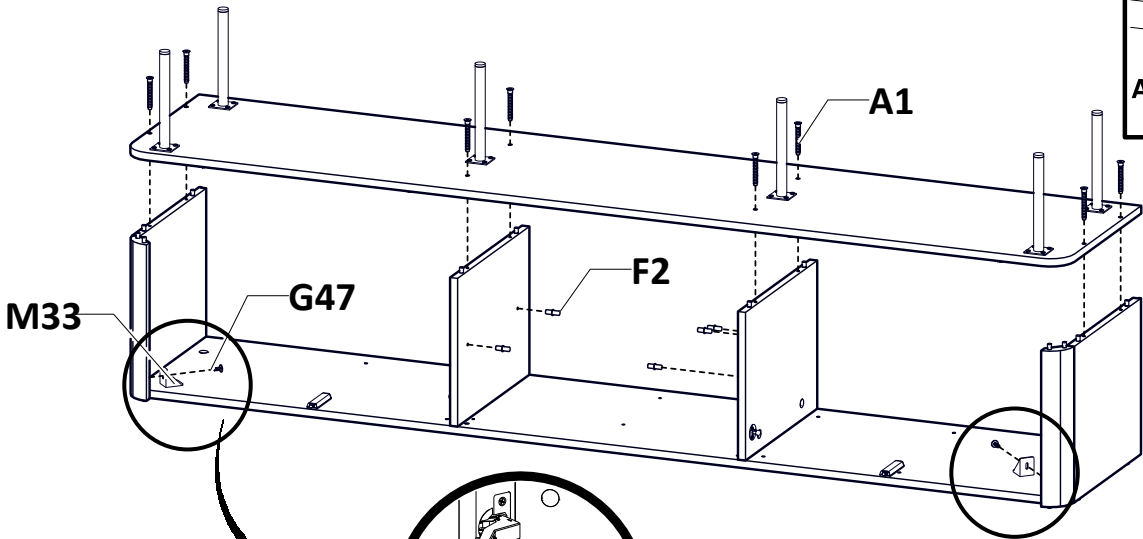
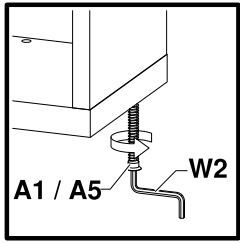

VIII

B

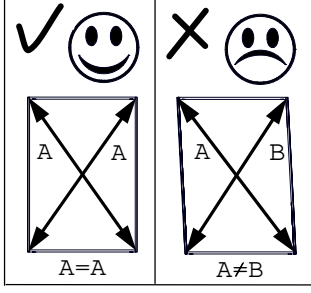
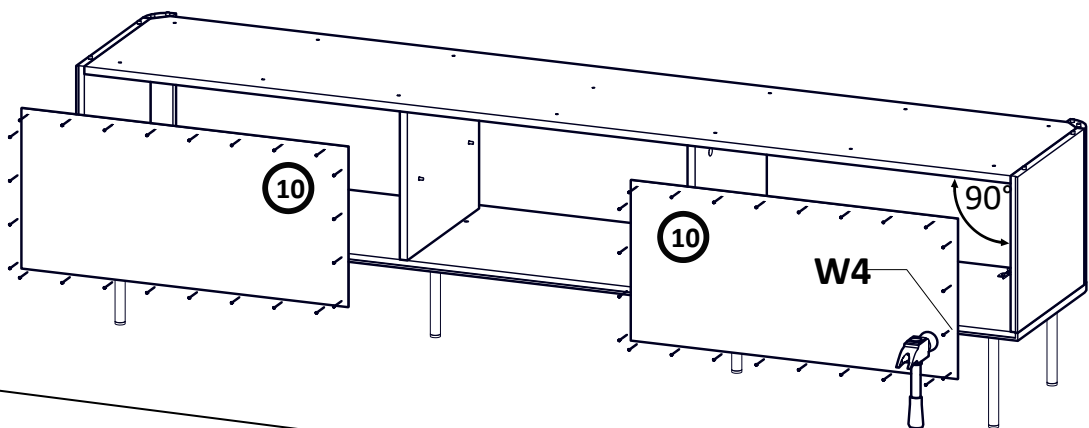
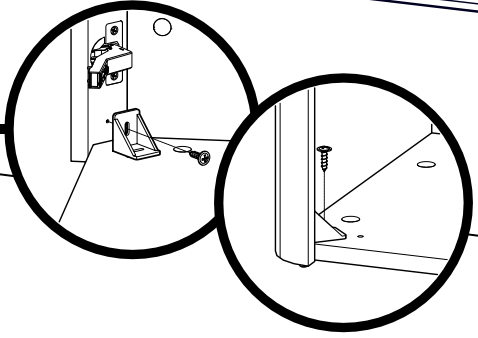

IX

B

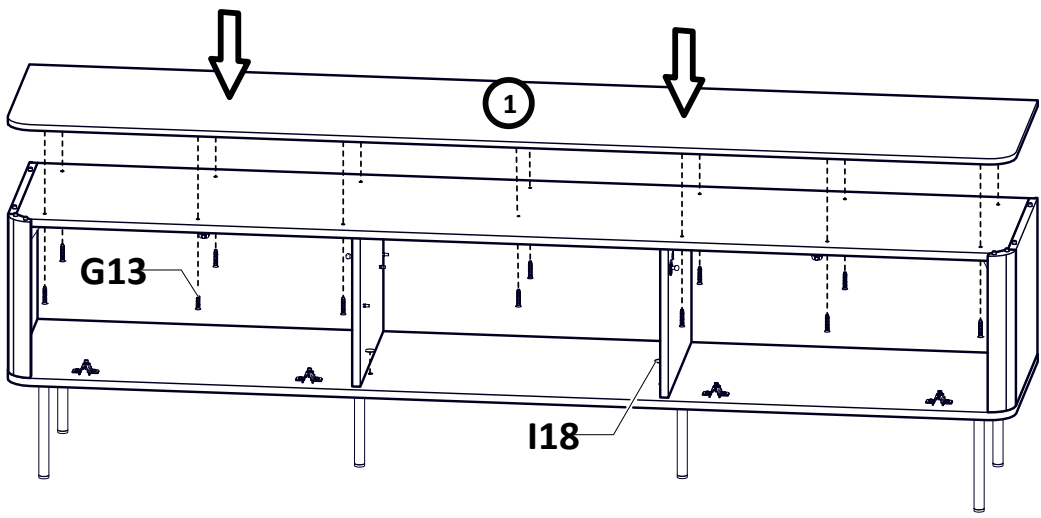

X

B

